



# Double Duty® 6

Steam Trap/Pump Combination



Condensate Recovery Equipment

### Description

Armstrong's Double Duty® Series steam trap/pump combination offers a low profile solution to draining heat exchangers in various applications.

The Double Duty® 6 is a CE marked carbon steel vessel according to PED 97/23 EC. The Double Duty® 6 offers you the versatility of combining a pump within a steam trap to aide in condensate drainage under all operating conditions.

### Features

- Economical. non-electric operation
- Low-maintenance operation. No leaking seals, impeller or motor problems. No NPSH issues.
- Space-saving size. Low-profile body fits in tight spaces while allowing minimal fill head.
- Lower installation costs. Single trade installation.
- Peace of mind. Intrinsically safe.
- Carbon Steel durability. Rugged construction material means long service life.
- Efficiency. A closed loop means no motive or flash steam is lost. All valuable heat is captured and returned to the system.
- Safety. The trap/pump can be used in pits or sumps without fear of electrocution or circuit breaker defaults.



Double Duty® 6

### Maximum Operating Conditions

Maximum allowable pressure:  
 EDD-6 14 bar @ 204°C

Maximum operating pressure:  
 EDD-6 14 bar @ 204°C

### Materials

Body: Carbon Steel  
 Springs: Inconel X-750  
 Internals: All stainless steel

Table CRE-236-1. EDD-6 Pumping Trap Physical Data		
Model Number	EDD-6	
	DIN	ANSI
"A"	887	920
"B"	DN40	1-1/2"
"C"	DN25	1"
"D"	1" BSPT	1" NPT
"E"	1/2" BSPT	1/2" NPT

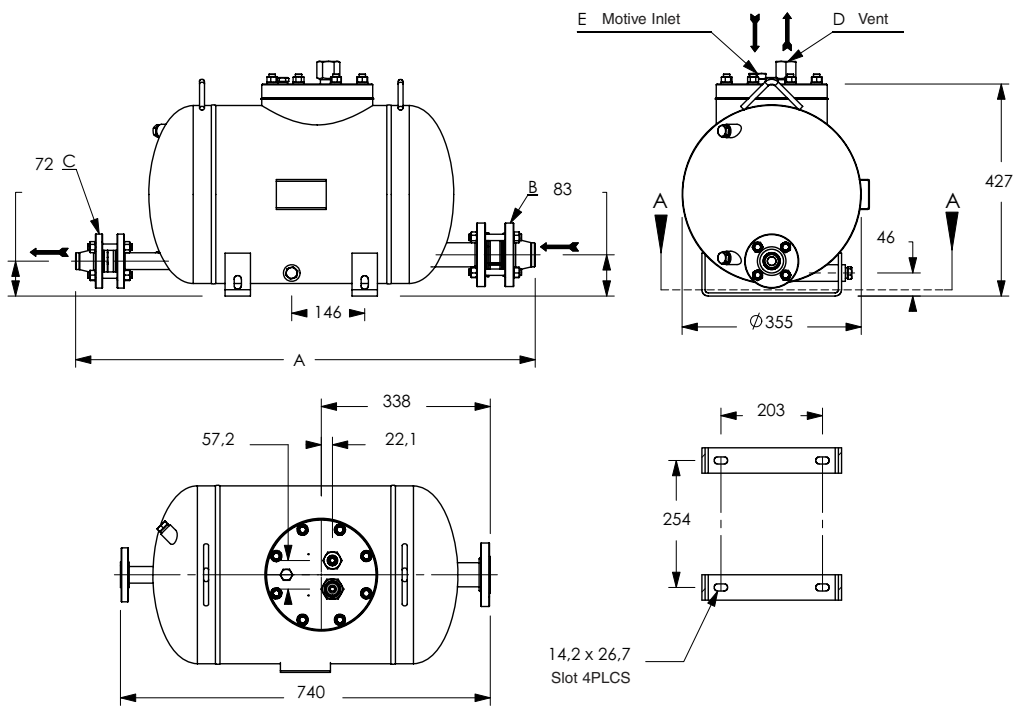

All dimensions and weights are approximate. Use certified print for exact dimensions. Design and materials are subject to change without notice.



## Double Duty® 6

Steam Trap/Pump Combination



Motive	Back Pressure	Capacity
bar	bar	kg/hr
1	0,34	1 089
1,7		1 361
3,5		1 814
5		2 041
7		2 087
8,5		2 132
10,34		2 177
12		2 177
14		2 087
1,7		1
3,5	1 270	
5	1 542	
7	1 633	
8,5	1 678	
10,34	1 724	
12	1 633	
14	1 588	
2,5	1,7	816
3,5		1 043
5		1 315
7		1 361
8,5		1 361
10,34		1 315
12		1 134
14	1 043	
3,5	3	635
5		907
7		1 089
8,5		1 134
10,34		1 134
12		816
14	771	
5	4	680
7		816
8,5		907
10,34		771
12		680
14		635

**Note** : Published capacities are based on the use of external check valves supplied by Armstrong. Fill head measured from drain point to top of pump case.

Differential Pressure	Capacity
bar	kg-hr
0,14	4 309
0,34	5 625
0,7	6 804
1,7	9 253
3,5	10 206
5,2	10 206
6,9	10 206
10,3	10 206
13,8	10 206

mm	Filling Head			
	0	150	300	* 600 or greater
Double Duty EDD-6	0,7	1,0	1,08	* 620 or greater Consult factory

\* Discharge per cycle typically 13,6 litres for EDD-6  
**Note** : Fill head measured from drain to top of cap.

Condensate Recovery  
Equipment