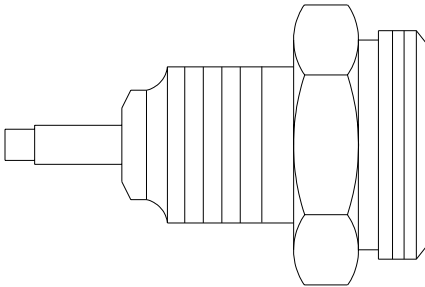

CP10
Sensor**Installation and Maintenance Instructions**

**CHRYSSAFIDIS**

- 1. Safety information*
- 2. General product information*
- 3. Installation*
- 4. Maintenance*
- 5. Spare parts*

1. Safety information

Safe operation of these products can only be guaranteed if they are properly installed, commissioned, used and maintained by qualified personnel (see Section 1.11) in compliance with the operating instructions. General installation and safety instructions for pipeline and plant construction, as well as the proper use of tools and safety equipment must also be complied with.

Do not install the probe outdoors without additional weather protection.

Drain/vent holes must be kept clean - do not cover.

1.1 Intended use

Referring to the Installation and Maintenance Instructions, name-plate and Technical Information Sheet, check that the product is suitable for the intended use/application. The products comply with the requirements of the European Pressure Equipment Directive 97/23/EC and fall within category 'SEP'. It should be noted that products within this category are required by the directive not to carry the CE mark.

- i) The products have been specifically designed for use on steam and water, which are in Group 2 of the above mentioned Pressure Equipment Directive. The products' use on other fluids may be possible but, if this is contemplated, Spirax Sarco should be contacted to confirm the suitability of the product for the application being considered.
- ii) Check material suitability, pressure and temperature and their maximum and minimum values. If the maximum operating limits of the product are lower than those of the system in which it is being fitted, or if malfunction of the product could result in a dangerous overpressure or overtemperature occurrence, ensure a safety device is included in the system to prevent such over-limit situations.
- iii) Determine the correct installation situation and direction of fluid flow.
- iv) Spirax Sarco products are not intended to withstand external stresses that may be induced by any system to which they are fitted. It is the responsibility of the installer to consider these stresses and take adequate precautions to minimise them.
- v) Remove protection covers from all connections and protective film from all name-plates, where appropriate, before installation on steam or other high temperature applications.

1.2 Access

Ensure safe access and if necessary a safe working platform (suitably guarded) before attempting to work on the product. Arrange suitable lifting gear if required.

1.3 Lighting

Ensure adequate lighting, particularly where detailed or intricate work is required.

1.4 Hazardous liquids or gases in the pipeline

Consider what is in the pipeline or what may have been in the pipeline at some previous time. Consider: flammable materials, substances hazardous to health, extremes of temperature.

1.5 Hazardous environment around the product

Consider: explosion risk areas, lack of oxygen (e.g. tanks, pits), dangerous gases, extremes of temperature, hot surfaces, fire hazard (e.g. during welding), excessive noise, moving machinery.

1.6 The system

Consider the effect on the complete system of the work proposed. Will any proposed action (e.g. closing isolation valves, electrical isolation) put any other part of the system or any personnel at risk?

Dangers might include isolation of vents or protective devices or the rendering ineffective of controls or alarms. Ensure isolation valves are turned on and off in a gradual way to avoid system shocks.

1.7 Pressure systems

Ensure that any pressure is isolated and safely vented to atmospheric pressure. Consider double isolation (double block and bleed) and the locking or labelling of closed valves. Do not assume that the system has depressurised even when the pressure gauge indicates zero.

1.8 Temperature

Allow time for temperature to normalise after isolation to avoid danger of burns.

If parts made from the PTFE have been subjected to a temperature approaching 260°C (500°F) or higher, they will give off toxic fumes, which if inhaled are likely to cause temporary discomfort. It is essential for a no smoking rule to be enforced in all areas where PTFE is stored, handled, or processed as persons inhaling the fumes from burning tobacco contaminated with PTFE particles can develop 'polymer fume fever'.

1.9 Tools and consumables

Before starting work ensure that you have suitable tools and/or consumables available. Use only genuine Spirax Sarco replacement parts.

1.10 Protective clothing

Consider whether you and/or others in the vicinity require any protective clothing to protect against the hazards of, for example, chemicals, high/low temperature, radiation, noise, falling objects, and dangers to eyes and face.

1.11 Permits to work

All work must be carried out or be supervised by a suitably competent person. Installation and operating personnel should be trained in the correct use of the product according to the Installation and Maintenance Instructions.

Where a formal 'permit to work' system is in force it must be complied with. Where there is no such system, it is recommended that a responsible person should know what work is going on and, where necessary, arrange to have an assistant whose primary responsibility is safety.

Post 'warning notices' if necessary.



1.12 Handling

Manual handling of large and/or heavy products may present a risk of injury. Lifting, pushing, pulling, carrying or supporting a load by bodily force can cause injury particularly to the back. You are advised to assess the risks taking into account the task, the individual, the load and the working environment and use the appropriate handling method depending on the circumstances of the work being done.

1.13 Residual hazards

In normal use the external surface of the product may be very hot. If used at the maximum permitted operating conditions the surface temperature of some products may reach temperatures of 239°C (462°F).

Many products are not self-draining. Take due care when dismantling or removing the product from an installation (refer to 'Maintenance instructions').

1.14 Freezing

Provision must be made to protect products which are not self-draining against frost damage in environments where they may be exposed to temperatures below freezing point.

1.15 Disposal

Unless otherwise stated in the Installation and Maintenance Instructions, this product is recyclable and no ecological hazard is anticipated with its disposal providing due care is taken, except:

PTFE:

- Can only be disposed of by approved methods, not incineration.
- Keep PTFE waste in a separate container do not mix it with other rubbish, and consign it to a landfill site.

1.16 Returning products

Customers and stockists are reminded that under EC Health, Safety and Environment Law, when returning products to Spirax Sarco they must provide information on any hazards and the precautions to be taken due to contamination residues or mechanical damage which may present a health, safety or environmental risk. This information must be provided in writing including Health and Safety data sheets relating to any substances identified as hazardous or potentially hazardous.



2. General product information

403322A 5/8

2.1 General product description

The CP10 sensor is a conductivity probe specified for use in total dissolved solids (TDS) and conductivity control systems.

It is a sealed unit consisting of a central stainless steel sensor tip, PEEK insulator, PTFE sealing ring, stainless steel body, disc springs and washer.

The sensor is threaded 2" BSP parallel for mounting in a sensor chamber, and has a 24 mm A/F hexagon. It is supplied with an S-type stainless steel gasket.

Electrical connection is via an IP65 connector (supplied separately).

The CP10 sensor and PT2 plug tail are intended for use with a low voltage limited power source. These are approved by Underwriters Laboratory as Listed accessories for use with Spirax Sarco controllers.

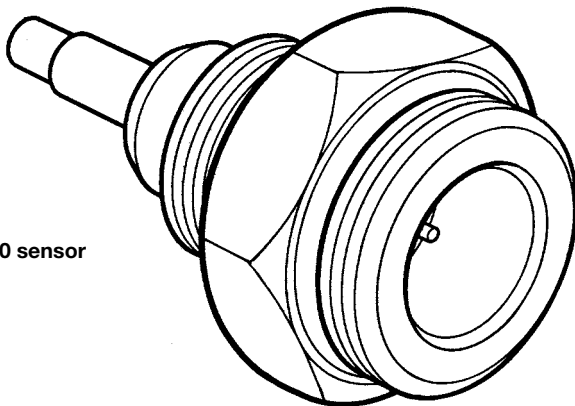

Fig. 1 CP10 sensor

2.2 Pressure/temperature limits

Body design	PN40
Maximum pressure/temperature	32 bar g at 239°C (464 psi g at 462°F)
Designed for a maximum cold hydraulic test pressure of:	60 bar g (870 psi g)
Minimum conductivity generally	10 μ S/cmm or 10 ppm, but see controller IMI.



3. Installation

Caution: Do not install the sensor outdoors without additional weather protection. Fit the sensor chamber in a vertical or horizontal pipeline with suitable isolation valves to allow inspection/cleaning of the sensors. Reducers may be fitted if required. Flow can be in either direction. The sensors themselves must be horizontal.

The TP20 has a taper thread, and may be installed using PTFE sealing tape if required.

The CP10 sensor is provided with an S-type stainless steel gasket for sealing. PTFE tape may be used on the CP10 threads, but check that the resistance to earth is less than 1Ω after installation.

Fit the sensors to the chamber and tighten to a torque of 60 N m (44 lbf ft).

Fit PT2 plug tail (or other Spirax Sarco plug tail) to the CP10 sensor and tighten.

Caution: Ensure the PT2 wire is not exposed to a temperature greater than 120°C (248°F).

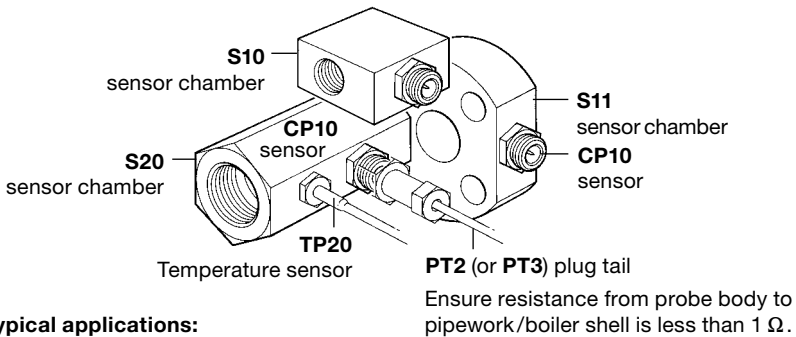

3.1 Electrical installation

Cabling should be installed in accordance with BS 6739 - Instrumentation in Process Control Systems: Installation design and practice or local equivalent.

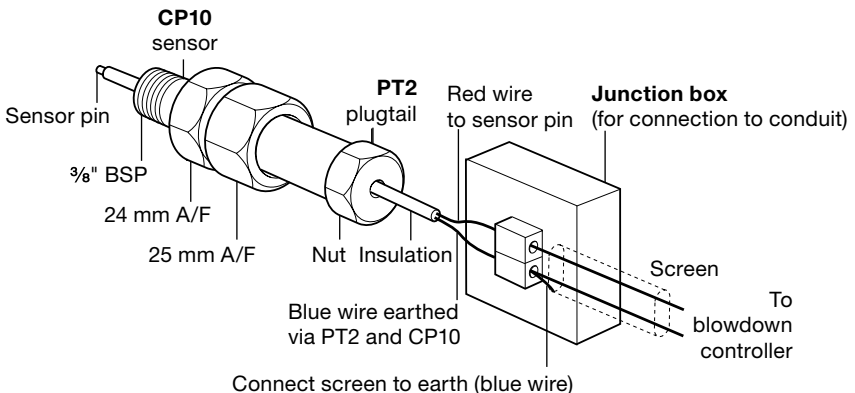

4. Maintenance

We recommend that the CP10 is removed for cleaning and inspection at least once a year, though the frequency of maintenance will depend on the quality and flowrate of the boiler water or condensate.

- Isolate and depressurise the system, (or with the system empty), remove the CP10 sensor.
- Inspect male and female threads for signs of damage, which may have occurred through overtightening, leading to torn threads or even localised cold welding (galling / picking up). If damage has occurred replace the CP10 sensor.
- If after inspection there is no damage to the thread proceed to clean the sensor tip with fine wet-or-dry paper, and the insulator with a cloth or bristle (not wire) brush.
- Inspect the insulator and sensor tip for erosion, damage, or pitting, and refit or replace as necessary.
- Retighten the CP10 sensor to a torque of 60 N m (44 lbf ft). **Note:** Always fit a new gasket.



CHRYSSAFIDIS

5. Spare parts

The spare parts available are detailed below. No other parts are supplied as spares.

Available spares

Gasket	Stock No. 0957191	Pack of 10
Spirax Sarco CP10 sensor and gasket	Stock No. 0861079	Set of 1

How to order spares

Always order spares by using the description given in the column headed 'Available spares' and state which product they are for.

Example 1: 1 off Spirax Sarco CP10 sensor and gasket - Stock number 0861079.

or

Example 2: 1 off Gasket (pack of 10) for a Spirax Sarco CP10 sensor - Stock number 0957191.



CHRYSSAFIDIS

CHRYSSAFIDIS S.A./ ATHENS: 3 AGRINIOU STR, TAVROS - (+30) 210 4836315-20 /
THESSALONIKI: DA12A STR, OT32, BIPE SINDOU - (+30) 2310 754681-4 /
www.chryssafidis.com / sales@chryssafidis.gr