



CHRYSSAFIDIS

**spirax
sarco**

TI-P137-18
ST Issue 5

BSAT and BSA Bellows Sealed Stop Valves

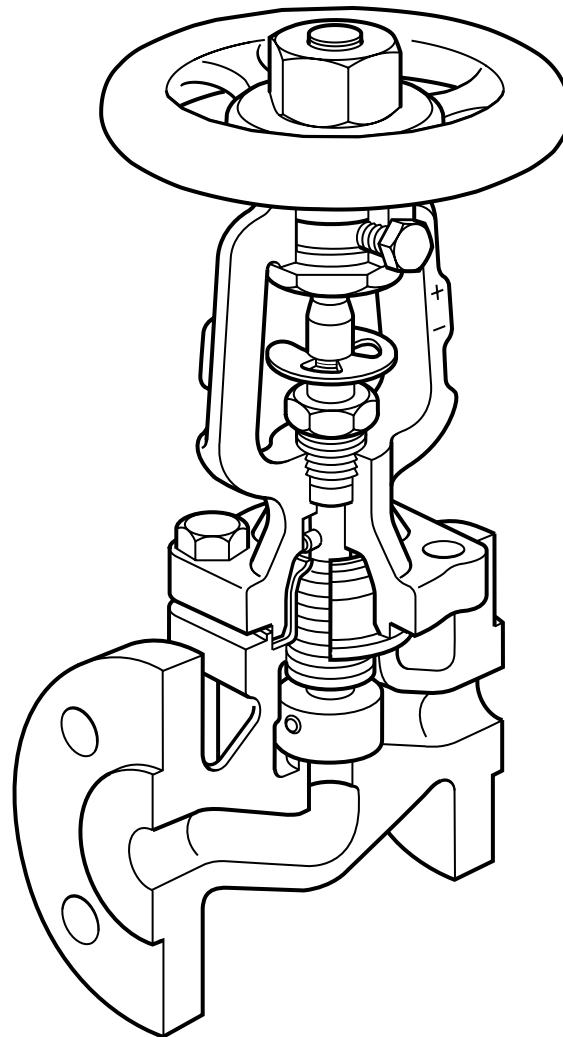

BSA6T shown

Description

A range of sealed, in-line stop valves having twin ply bellows as standard throughout the range. These valves have been designed for use on steam, gas, liquid, condensate and water systems.

The **standard BSAT** range comes complete with throttling plug and locking device.

The **alternative BSA** range has a flat disc.

The Tables on page 2 clearly display the available sizes, pipeline connections and available options for the standard and alternative ranges.

Standards

The product fully complies with the requirements of the European Pressure Equipment Directive 97/23/EC and carries the **CE** mark when so required.

Certification

The BSA1 and BSA1T is available with a manufacturer's Typical Test Report.

The BSA2, BSA2T, BSA3, BSA3T, BSA6T and BSA64T is available with certification to EN 10204 3.1. **Note:** All certification/inspection requirements must be stated at the time of order placement.

Range and options

Standard BSAT range - complete with throttling plug and locking device

Material		Cast iron		SG iron		Cast steel					Stainless steel	Stainless steel / cast steel
Model and connections		BSA1T		BSA2T		BSA3T					BSA6T	BSA64T
		PN16	KS 10	PN16	PN25	PN25	PN40	ASME 150	ASME 150	KS 20	PN40	PN40
Sizes	DN15	•	•	•	•		•	•	•	•	•	•
	DN20	•	•	•	•		•	•	•	•	•	•
	DN25	•	•	•	•		•	•	•	•	•	•
	DN32	•	•	•	•		•				•	•
	DN40	•	•	•	•		•	•	•	•	•	•
	DN50	•	•	•	•		•	•	•	•	•	•
	DN65	•	•	•	•		•				•	•
	DN80	•	•	•	•		•	•	•	•	•	•
	DN100	•	•	•	•		•	•	•	•	•	•
	DN125	•	•	•	•		•					
	DN150	•	•	•	•		•			•		
	DN200	•	•	•	•	•				•		
DN250				•								
Optional R-PTFE soft seat	DN15	•	•	•	•		•	•	•	•	•	•
	DN20	•	•	•	•		•	•	•	•	•	•
	DN25	•	•	•	•		•	•	•	•	•	•
	DN32	•	•	•	•		•				•	•
	DN40	•	•	•	•		•	•	•	•	•	•
	DN50	•	•	•	•		•	•	•	•	•	•
	DN65	•	•	•	•		•				•	•
	DN80	•	•	•	•		•	•	•	•	•	•
DN100	•	•	•	•		•	•	•	•	•	•	

Alternative BSA range - complete with flat disc option

Material		Cast iron		SG iron		Cast steel					Stainless steel	Stainless steel / cast steel
Model and connections		BSA1		BSA2		BSA3						
		PN16	KS 10	PN16	PN25	PN25	PN40	ASME 150	ASME 300	KS 20		
Sizes	DN125	•	•	•	•		•					
	DN150	•	•	•	•		•		•	•		
	DN200	•	•	•	•	•			•	•		
	DN250				•							
Optional balancing disc	DN125				•		•					
	DN150				•		•			•		
	DN200	•	•	•	•	•			•	•		
	DN250				•							



Dimensions/weights (approximate) in mm and kg

Size	A					B	C	Weight				
	PN	JIS/KS 10K	JIS/KS 20K	ASME 150	ASME 300			BSA1 BSA1T BSA2 BSA2T	BSA3 (DIN)	BSA3 (ASME) ANSI 150	BSA3 ASME 300 JIS/KS 20K	BSA6T BSA64T PN40
DN15	130	133	152	108	152	205	125	4	4	5	6	4
DN20	150	153	178	117	178	205	125	4	5	6	7	5
DN25	160	163	200	127	203	217	125	5	6	8	9	6
DN32	180	183	-	-	-	217	125	7	8	-	-	8
DN40	200	203	224	165	229	243	200	10	11	10	11	11
DN50	230	229	259	203	267	243	200	12	14	12	15	14
DN65	290	293	-	-	-	263	200	16	19	-	-	19
DN80	310	309	304	241	317	287	200	21	26	25	29	26
DN100	350	349	340	292	356	383	315	36	44	41	49	44
DN125	400	395	-	-	-	416	315	52	64	-	-	-
DN150	480	479	428	-	445	450	315	75	88	-	94	-
DN200	600	592	537	-	559	622	500	145	180	-	193	-
DN250	730	-	-	-	-	763	500	*180	-	-	-	-

*(BSA2T / BSA2 only)

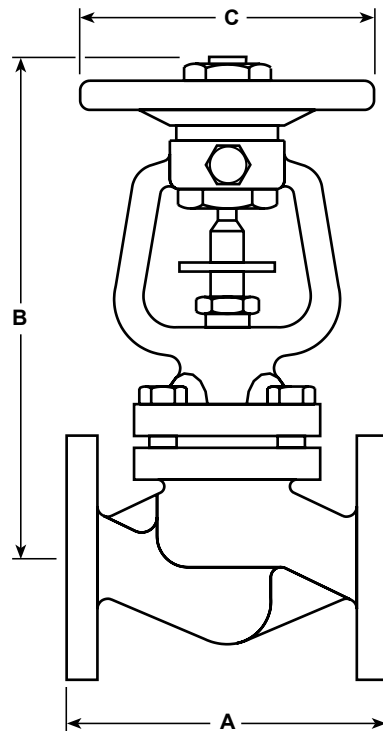

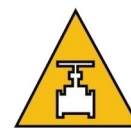

Seat leakage

Disc to seat shut-off conforms to EN 12266-1 Rate A leakage and ISO 5208 Rate A. Disc to seat shut-off for BSA3 (ANSI) conforms to API 598 no leakage.

K_v values - all options

Size	DN15 (½")	DN20 (¾")	DN25 (1")	DN32 (1¼")	DN40 (1½")	DN50 (2")	DN65 (2½")	DN80 (3")	DN100 (4")	DN125 (5")	DN150 (6")	DN200 (8")	DN250 (10")
K _v	4	7	12	19	30	47	77	120	193	288	410	725	1145

For conversion: C_v (UK) = K_v x 0.963 C_v (US) = K_v x 1.156

Note: For K_v values and flow characteristic values of the **BSA1T**, **BSA2T** and **BSA3T** see the next section 'BSAT flow data'.

BSAT flow data

Size	BSAT valve												
	DN15	DN20	DN25	DN32	DN40	DN50	DN65	DN80	DN100	DN125	DN150	DN200	DN250
Hand-wheel rotations	K _v values for given handwheel rotations tested to EN 60534-2-3 Water at 20°C												
0	0	0	0	0	0	0	0	0	0	0	0	0	0
0.5	1.2	1.2	1.4	2.2	4.4	4.1	5.6	10.4	12.0	21	28	66	110
1	1.7	1.7	2.0	3.7	5.0	5.0	7.0	11.5	14.3	23	30	81	140
1.5	2.7	2.9	2.9	5.0	5.5	6.0	9.2	13.6	24.5	26	33	97	150
2	3.6	4.0	4.6	7.9	7.6	7.2	11.6	16.3	34.1	42	46	111	165
2.5	4.4	5.3	6.4	10.6	11.0	9.7	12.4	18.5	59.6	67	65	149	190
3	5.4	6.6	8.5	13.8	14.7	14.1	13.0	21.1	86.2	94	90	199	225
4			10.6	17.0	22.6	24.4	25.2	24.5	123.0	140	152	302	330
4.5			11.2	18.3	24.4	29.4	32.5	29.0	139.0	181	177	355	451
5			11.9	19.6	27.2	37.0	43.6	39.1	164.1	185	216	403	460
6					28.9	46.2	60.2	61.0	179.0	220	264	455	600
6.5					29.1	47.0	63.0	69.0	186.0	230	288	480	641
6.7					29.3	47.2	64.3	73.0		235	293	487	656
7							65.9	78.0		241	305	495	678
8							71.2	90.0		259	337	507	738
8.5							74.6	92.0			348	522	760
9.5								99.0			369		793
10								101.6					805
10.7													827

To convert K_v to volume flowrate in m³/h:-

$$\dot{Q} = K_v \times \sqrt{\Delta P}$$

Where:

\dot{Q} = Volume flow in cubic m/h

ΔP = Pressure drop in bar

Note: The maximum recommended differential pressure in throttling function:

DN15 - DN80	2.0 bar
DN100 - DN125	1.5 bar
DN150	1.0 bar
DN200 - DN250	0.8 bar

If the BSAT is used above these quoted figures, increased noise and vibration may be experienced.

The graphs below show handwheel rotation and flow characteristic with water at 20°C:

BSAT - DN15

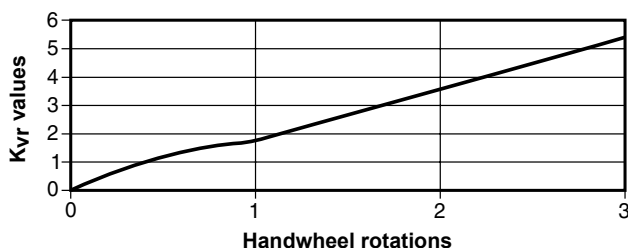

BSAT - DN20

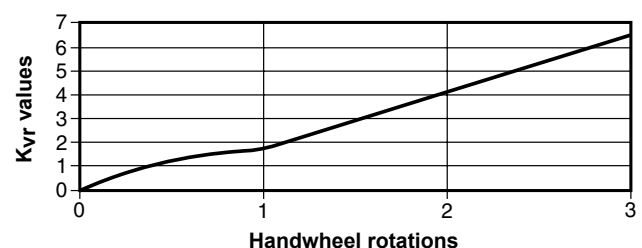

BSAT - DN25

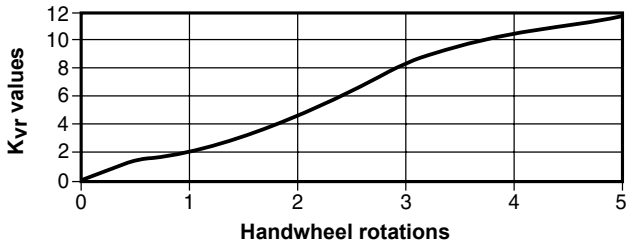

BSAT - DN32

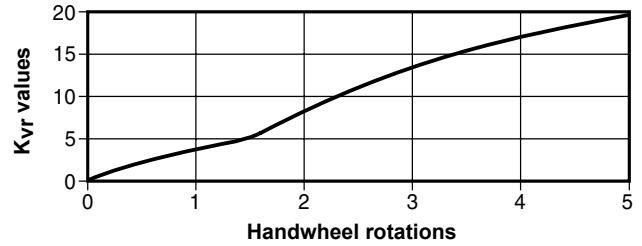

BSAT - DN40

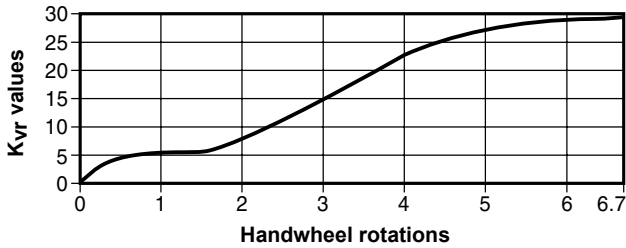

BSAT - DN50

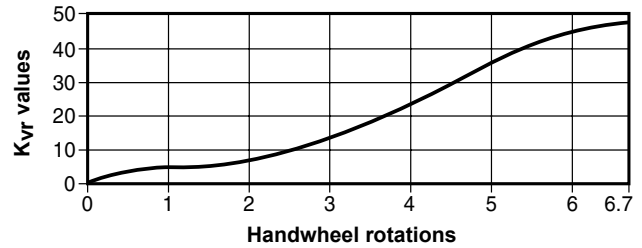

BSAT - DN65

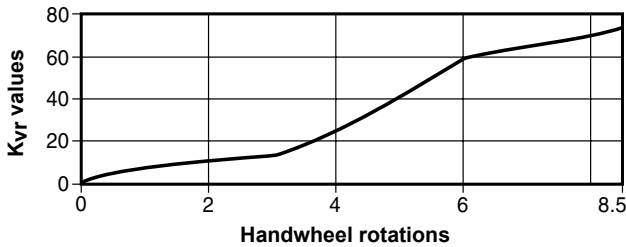

BSAT - DN80

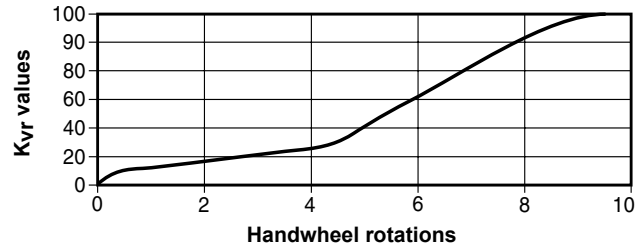

BSAT - DN100

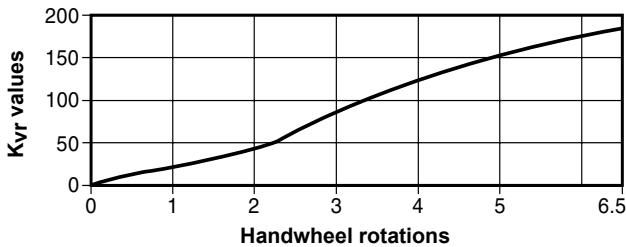

BSAT - DN125

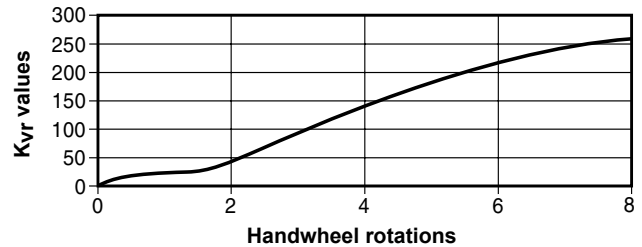

BSAT - DN150

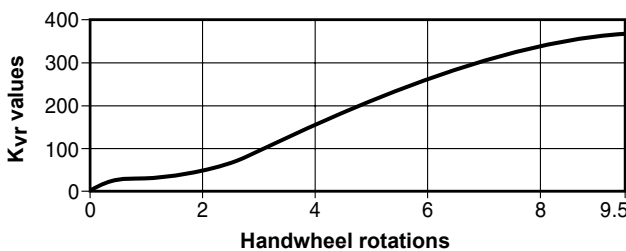

BSAT - DN200

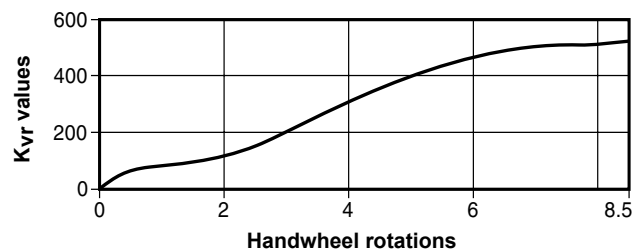

BSAT - DN250

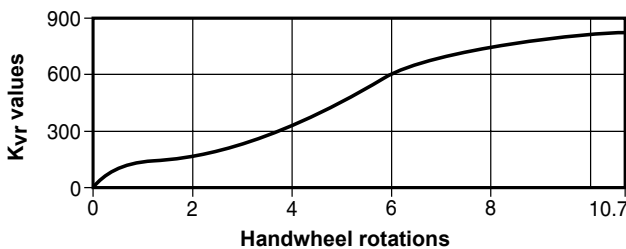

Typical standard flat disc for the BSA1, BSA2 and BSA3

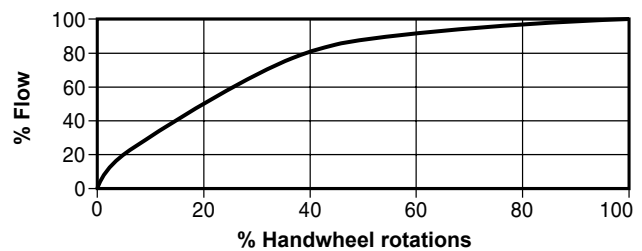

Materials for the BSA1T, BSA2T, BSA3T and BSA1, BSA2, BSA3

No. Part	BSA1T and BSA1	BSA2T and BSA2	BSA3T and BSA3	
			DIN	ANSI
1 Body	Cast iron EN-GJS-250	SG iron EN-GJS-400-18-LT	Cast steel 1.0619+N (GSC 25N)	Cast steel ASTM A 216 WCB
2 Bonnet	SG iron EN-GJS-400-18-LT		Steel (DN15 - DN80) DIN 17243 C 22.8	Forged steel (DN15- DN80) ASTM A 105
			Steel (DN100 - DN200) 1.0619+N (GSC 25N)	Cast steel (DN100- DN200) ASTM A 216 WCB
3 Seat	Stainless steel AISI 420			
4 Disc	Metal Stainless steel DIN 17440 X30 Cr13			
	Soft seat Stainless steel DIN 17440 X30 Cr13			
	Disc Insert R-PTFE 25% carbon filled			
5 Bellows	Stainless steel DIN 17440 X6 Cr Ni Ti 1810			
6 Stem	Stainless steel AISI 420			
7 Handwheel	Pressed steel BS 1449 CR4			
8 Stem packing	Graphite			
Bonnet studs		Steel DIN 17420 24 Cr Mo 5	Steel ASTM A 193 B7	
9 Bonnet nuts		Steel DIN 17420 Ck 35	Steel ASTM A 192 2 H	
Bonnet bolts	Steel DIN 931 Gr. 5.6			
10 Body / bonnet gasket	Graphite laminated with stainless steel insert			
11 Locking screw	DN15 - DN80	Steel M8 x 14 mm BS 3692 Gr. 8.8		
	DN100 - DN150	Steel M8 x 20 mm BS 3692 Gr. 8.8		
	DN200 - DN250	Steel M12 x 20 mm BS 3692 Gr. 8.8		

Stroke limiter for throttling versions
The handwheel nut on the **BSA1T**, **BSA2T** and **BSA3T** has a threaded hole for provision of a stroke limiter. Customer to supply standard nuts and bolts as indicated in the table below.

Size	Hexagon bolt
DN15 - DN80	M8 x 50 mm
DN100 - DN150	M12 x 75 mm
DN200 - DN250	M12 x 100 mm

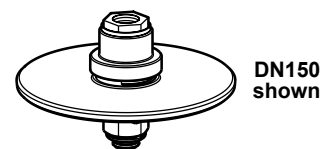
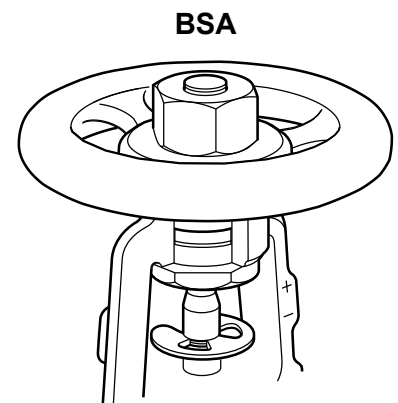
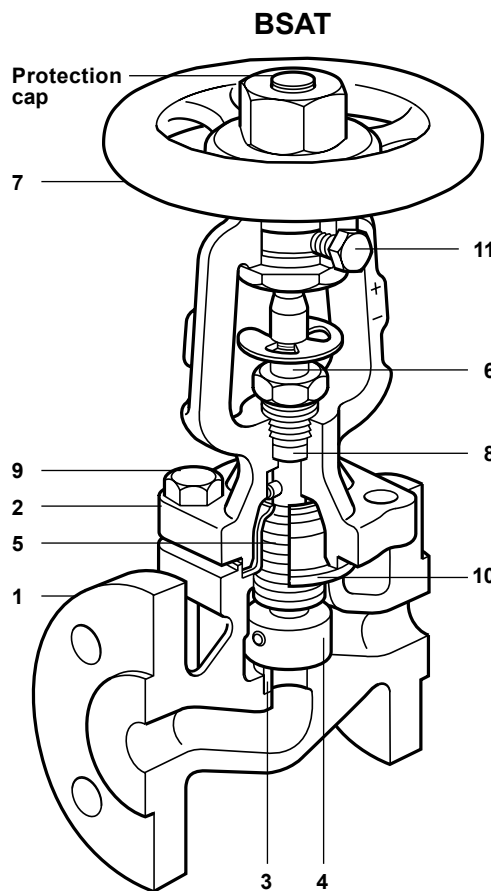
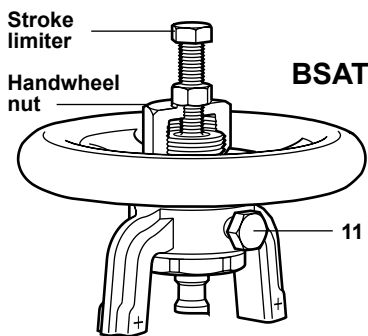

Optional balancing disc assembly

	25 bar ΔP DN125
Used	17 bar ΔP DN150 6"
above	10 bar ΔP DN200 8"
	6 bar ΔP DN250 (BSA2 only)



Optional soft sealing disc



Materials for the BSA6T and BSA64T

No. Part	BSA6T	BSA64T
1 Body	Stainless steel EN 10213 1.4408 or ASTM A351 CF8M	Stainless steel EN 10213 1.4408 or ASTM A351 CF8M
2 Bonnet	Stainless steel EN 10213 1.4581	Carbon steel DN15 - DN80 DIN 117243 C22.8 Carbon steel DN100 10619+N (GSC 25N)
3 Seat	Stainless steel EN 10213 1.4408 or ASTM A351 CF8M	
4 Disc	DN15 - DN40	Stainless steel EN 10088 1.4571
	DN50 - DN100	Stainless steel EN 100222 1.4571
5 Bellows	Stainless steel DIN 17440 1.4571	
6 Stem	Stainless steel EN 10088 1.4571	
7 Handwheel	Pressed steel BS 1449 CR4	
8 Stem packing	Graphite	
Bonnet studs	Stainless steel A4-70	
9 Bonnet nuts	Stainless steel A4	
10 Body / bonnet gasket	Graphite laminated with stainless steel insert	
11 Locking screw	DN15 - DN80	Steel M8 x 14 mm A2-70
	DN100 - DN150	Steel M8 x 20 mm A2-70
	DN200 - DN250	Steel M12 x 20 mm A2-70

Stroke limiter for throttling versions
The handwheel nut on the **BSA6T** and **BSA64T** has a threaded hole for provision of a stroke limiter. Customer to supply standard nuts and bolts as indicated in the table below.

Size	Hexagon bolt
DN15 - DN80	M8 x 50 mm
DN100 - DN150	M12 x 75 mm
DN200 - DN250	M12 x 100 mm

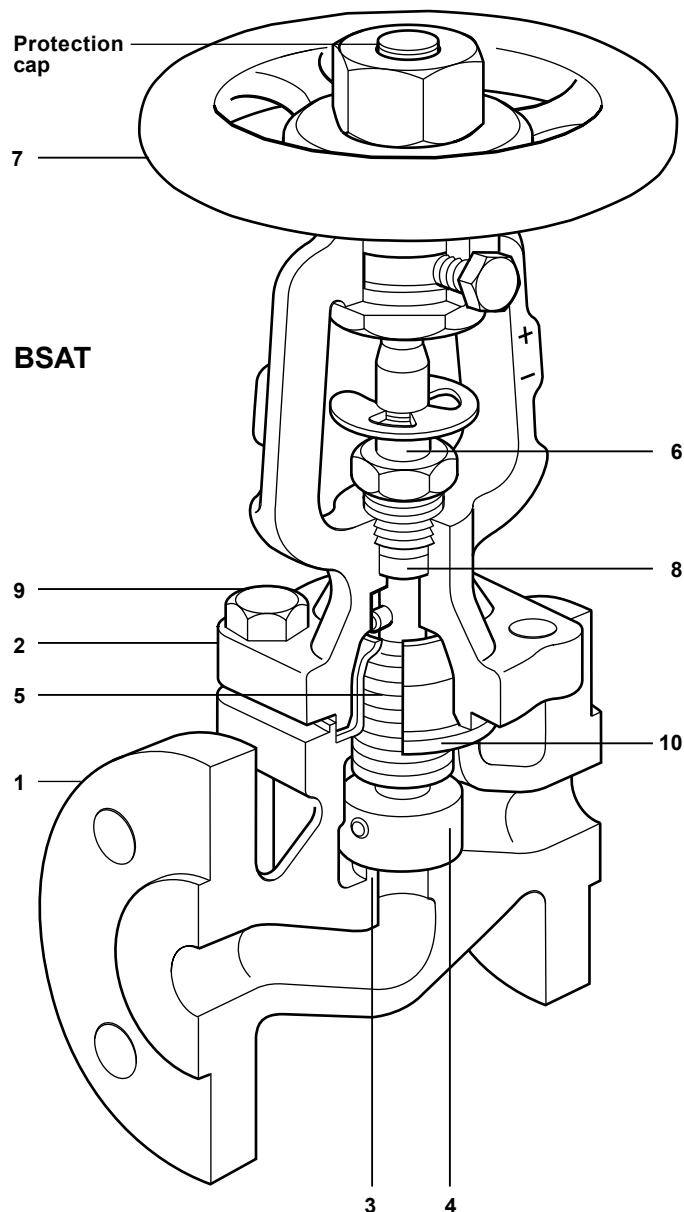
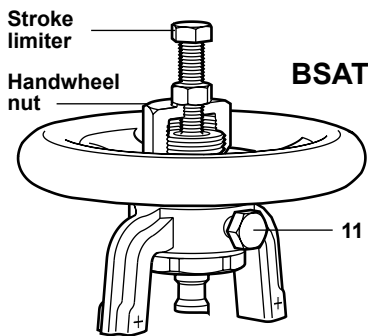

Product limitations

Key: The product must not be used in this region.	Maximum permissible differential pressure in throttling function:			
	DN15 - DN80	2.0 bar	DN150	1.0 bar
Note: ΔPMX Maximum differential pressure is limited to the PMO.	DN100 - DN125	1.5 bar	DN200 - DN250	0.8 bar

BSA1T and BSA1

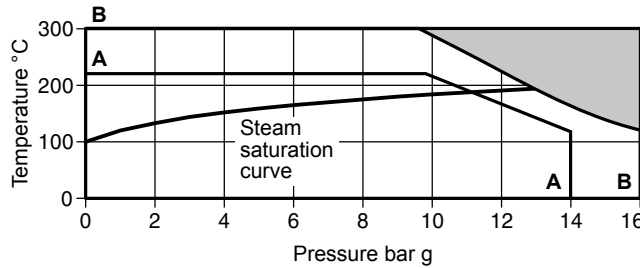

A - A Flanged JIS / KS 10K
B - B Flanged PN16

Body design conditions	PN16	JIS / KS 10K
PMA - Maximum allowable pressure	16 bar g	14 bar g
TMA - Maximum allowable temperature	300°C	220°C
PMO - Maximum operating pressure for saturated steam service	12.9 bar g	11 bar g
TMO - Maximum operating temperature	Soft seat	230°C
	Metal seat	300°C
Minimum operating temperature	-10°C	-10°C
Designed for a maximum cold hydraulic test pressure of:	24 bar g	20 bar g

BSA2T and BSA2

PN16

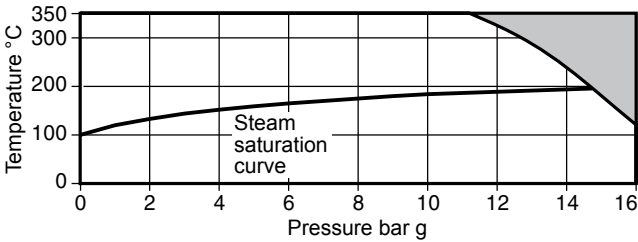

PN25

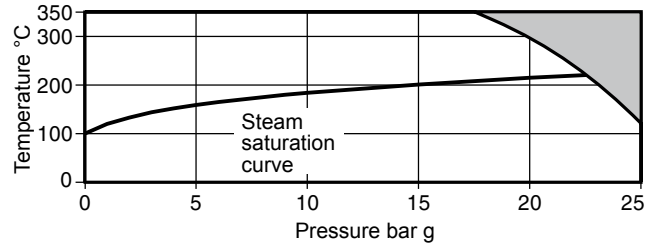

Body design conditions	PN16	PN25
PMA - Maximum allowable pressure	16 bar g	25 bar g
TMA - Maximum allowable temperature	350°C	350°C
PMO - Maximum operating pressure for saturated steam service	14.7 bar g	22.3 bar g
TMO - Maximum operating temperature	Soft seat	230°C
	Metal seat	350°C
Minimum operating temperature	-10°C	-10°C
Designed for a maximum cold hydraulic test pressure of:	24 bar g	38 bar g

BSA3T and BSA3 (DIN)

PN25, DN200

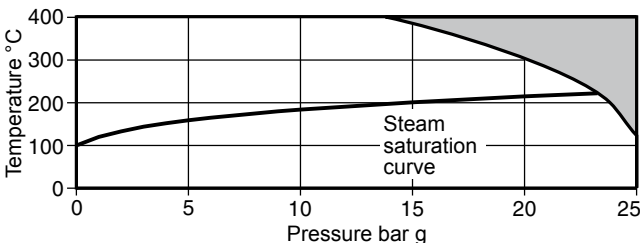

PN40, DN15 - DN150

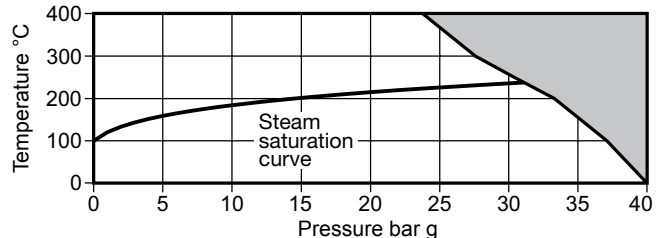

Body design conditions	PN25, DN200	PN40, DN15 - DN150
PMA - Maximum allowable pressure	25 bar g	40 bar g
TMA - Maximum allowable temperature	400°C	400°C
PMO - Maximum operating pressure for saturated steam service	23.2 bar g	* 30.4 bar g
TMO - Maximum operating temperature	Soft seat	230°C
	Metal seat	400°C
Minimum operating temperature	-10°C	-10°C
Designed for a maximum cold hydraulic test pressure of:	38 bar g	60 bar g

* Maximum operating pressure is limited to 27 bar g for the soft seat version only

Product limitations

Key: The product **must not** be used in this region.

Maximum permissible differential pressure in throttling function:

Note: Δ PMX Maximum differential pressure is limited to the PMO.

DN15 - DN80	2.0 bar	DN150	1.0 bar
DN100 - DN125	1.5 bar	DN200 - DN250	0.8 bar

BSA3T and BSA3 (ASME)

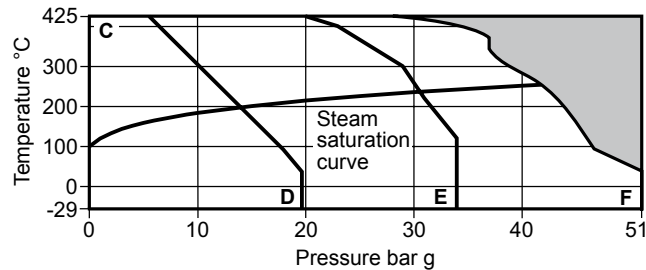

C - D Flanged ASME 150
C - E Flanged JIS / KS 20K
C - F Flanged ASME 300

Body design conditions	ASME 150	ASME 300	JIS/KS 20K
PMA - Maximum allowable pressure	19.6 bar g	51 bar g	34 bar g
TMA - Maximum allowable temperature	425°C	425°C	425°C
PMO - Maximum operating pressure for saturated steam service	14 bar g	*41.6 bar g	*30.7 bar g
TMO - Maximum operating temperature	Soft seat	230°C	230°C
	Metal seat	425°C	425°C
Minimum operating temperature	-29°C	-29°C	0°C
Designed for a maximum cold hydraulic test pressure of:	31 bar g	77 bar g	50 bar g

* Maximum operating pressure is limited to 27 bar g for the soft seat version only

BSA6T and BSA64

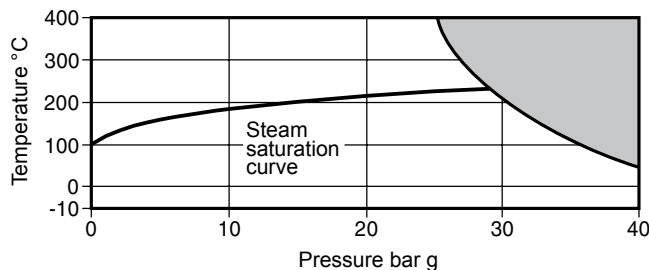

Body design conditions	PN40		
PMA - Maximum allowable pressure	40 bar g @ 50°C		
TMA - Maximum allowable temperature	400°C @ 25 bar g		
Minimum allowable temperature	-10°C		
PMO - Maximum operating pressure for saturated steam service	Metal seat	29.8 bar g @ 236°C	
	Soft seat	27.0 bar g @ 230°C	
TMO - Maximum operating temperature	Metal seat	400°C @ 25.6 bar g	
	Soft seat	230°C @ 27.0 bar g	
Minimum operating temperature	-10°C		
Δ PMX - Maximum differential pressure	On/off function	Limited to the PMO	
	Throttling function	DN15 - DN80	2 bar
		DN100	1.5 bar
Designed for a maximum cold hydraulic test pressure of:	60 bar g		



Safety information, installation and maintenance

For full details see the Installation and Maintenance Instructions (IM-P137-02) supplied with the product.

Installation note: Install in the direction of flow given by the arrow on the body with the handwheel in a suitable position.

Disposal: These products are recyclable. No ecological hazard is anticipated with the disposal of these products, providing due care is taken.

How to order

Example: 1 off DN25 Spirax Sarco type BSA2T bellows sealed stop valve, flanged PN16 or PN25.

Note: Should the differential pressure exceed those listed against the respective sizes in the table below, then please ensure balancing discs are specified for use in the valves (see illustration overleaf).

Size	DN125	DN150	DN200	DN250
Differential pressure (bar)	25	17	10	6

Spare parts

The spare parts are shown in heavy outline. Parts drawn in broken line are not supplied as spares.

Available spares

Body/bonnet gasket and stem packing	10, 8 (2 off)
Stem and bellows assembly (state if BSAT or BSA)	5, 6, 8, 10
Disc (and optional disc where fitted) - state full description of the valve	4, 8, 10

How to order spares

Please note: for customer convenience spares are supplied in kits to ensure all the appropriate replacement parts are supplied to carry out a specific maintenance task. e.g. when a stem/bellows assembly is ordered, parts (10), (8) and (6, 5) will be included in the kit.

Always order spares by using the description given in 'Available spares' and state the size and type of stop valve.

Example: 1 - Body / bonnet gasket and stem packing for a DN15 Spirax Sarco BSA2T PN16 bellows sealed stop valve.

