



Cert. No. LRQ 0963008

ISO 9001

spirax sarco

TI-P612-28
ST Issue 4

APT10-4.5 Automatic Pump Trap

Description

The Spirax Sarco automatic pump trap is a screwed displacement receiver pressure rated to PN10. The unit is capable of automatically trapping or pumping, depending on line conditions. The unit is operated by steam and is used to remove condensate from process and heating plant under all operating conditions including vacuum. The APT10-4.5 is available with standard blue paint finish or coated in ENP (Electroless Nickel plate).

Certification

This product is available with certification to EN 10204 3.1. **Note:** All certification/inspection requirements must be stated at the time of order placement.

Standards

This product fully complies with the requirements of the European Pressure Equipment Directive 97/23/EC, ATEX Directive 94/9/EC and carries the **CE** and **Ex** marks when so required.

Design compliance

Shell designed in accordance with A.D. Merkblätter / ASME VIII.

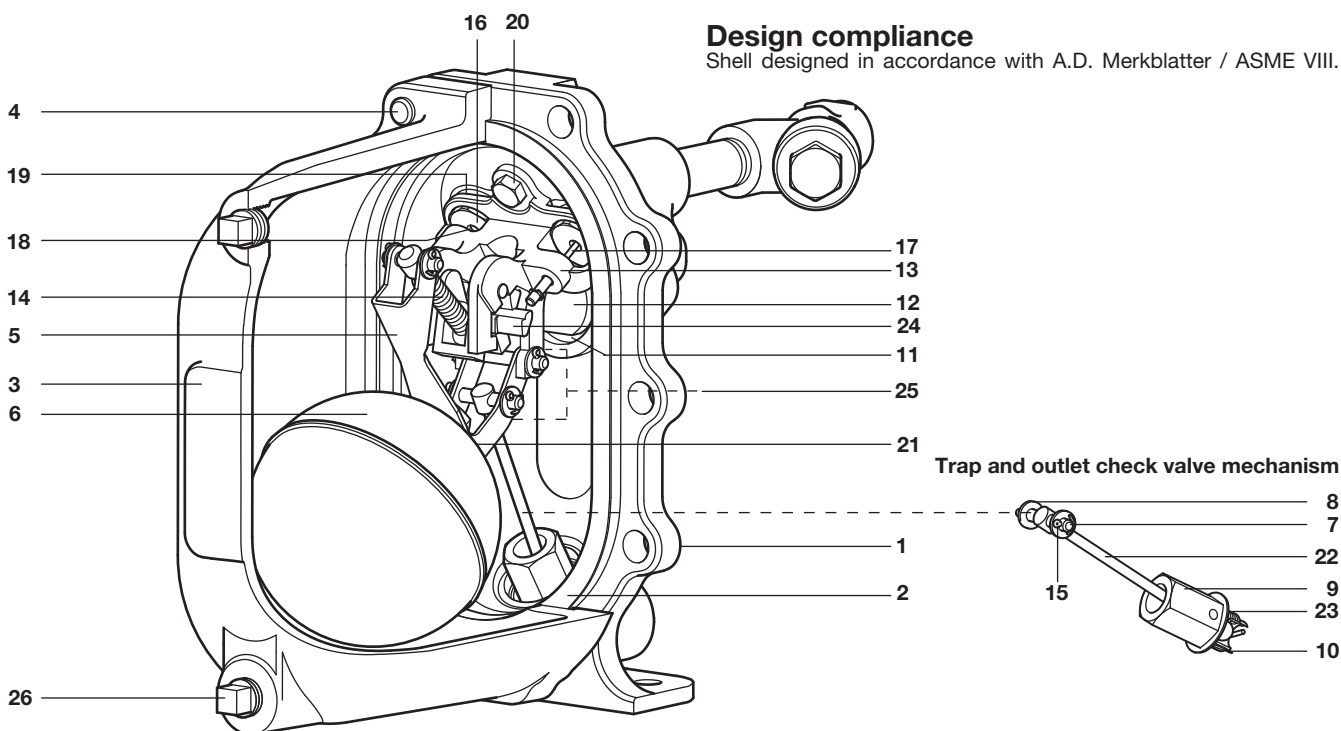

Materials

No. Part	Material	
1	Cover	SG iron EN JS 1025 / ASTM A395
2	Cover gasket	Synthetic fibre
3	Body	SG iron EN JS 1025 / ASTM A395
4	Cover bolts	Stainless steel BS EN ISO 3506 Gr.A2-70
5	Pump trap lever	Stainless steel BS 1449 304 S15
6	Float	Stainless steel BS 1449 304 S16
7	Pivot shaft	Stainless steel BS 970 431 S29 ASTM A276 431
8	Washer	Stainless steel BS 1449 316
9	Trap housing	Stainless steel BS 970 431 S29 ASTM A276 431
10	Ball	Stainless steel ASTM A276 440 B
11	Seat (inlet check valve)	Stainless steel AISI 420
12	Flap (inlet check valve)	Stainless steel BS 3146 ANC 4B
13	Pump mechanism bracket	Stainless steel BS 3146 ANC 4B

No. Part	Material	
14	Spring (pump)	Stainless steel BS 2056 302 S26 Gr. 2
15	Split pin	Stainless steel BS 1574
16	Exhaust seat	Stainless steel BS 970 431 S29 / ASTM A276 431
17	Inlet valve and seat assembly	Stainless steel ASTM A276 440 B / BS 970 431 S29
18	Exhaust valve	Stainless steel BS 3146 ANC 2
19	Valve seat gasket	Stainless steel BS 1449 409 S19
20	Pump mechanism bolt	Stainless steel BS EN ISO 3506 Gr.A2-70
21	Float bolt	Stainless steel BS EN ISO 3506 Gr.A2-70
22	Trap 1st stage valve	Stainless steel BS 970 431 S29 / ASTM A276 431
23	Trap gasket	Stainless steel BS 1449 409 S19
24	Actuator arm	Stainless steel BS 3146 ANC 2
25	Name-plate	Stainless steel BS 1449 304 S16
26	Drain plug	Stainless steel DIN 17440 1.4571
27	Motive supply strainer	SG iron DIN 17440 1.4571

Local regulations may restrict the use of this product to below the conditions quoted.

In the interests of development and improvement of the product, we reserve the right to change the specification without notice.

© Copyright 2007

Sizes and pipe connections

Size		DN20 x DN20
Fluid connections		
Inlet	Outlet	Motive/Exhaust
DN20 (¾")	DN20 (¾")	DN15 (½")
BSP - BS 21 parallel		BSP
NPT		NPT

Limiting conditions

Body design conditions	PN10
Maximum motive inlet pressure	4.5 bar g
Maximum operating pressure	4.5 bar g
Maximum backpressure	4.0 bar g
Maximum operating temperature	155°C
Minimum operating temperature	-10°C
Temperature limits (Ambient ⊕)	-10°C to 200°C
Designed for a maximum cold hydraulic test pressure of 15.0 bar g	
Minimum installation head (from base of pump)	0.2 m
Recommended minimum installation head (from base of pump)	0.3 m

Safety information, installation and maintenance

For full details see the Installation and Maintenance Instructions supplied with the product.

Nominal capacities

For full capacity details for a specific application consult Spirax Sarco. To accurately size the pump trap, the following data is required.

1. Installation head available, from the base of the pump trap to the centre line of the heat exchanger / process condensate outlet (m). If the outlet is mounted vertically, then this should be from the base of the pump to the face of the outlet.
2. Motive steam pressure available to power the pump trap (bar g).
3. Total backpressure in the condensate return system (bar g). See note below.
4. Heat exchanger full load operating pressure (bar g).
5. Heat exchanger maximum steam load (kg/h).
6. Minimum temperature of secondary fluid (°C).
7. Maximum controlled temperature of secondary fluid (°C).

Size	DN20 x DN20
Pump discharge/cycle	2.6 litres
1.0 metre installation head	Max. trapping capacity 830 kg/h
At: 4.5 bar g motive pressure 2.5 bar g total backpressure	

Note:

Total lift or backpressure BP (static head plus pressure head in the return system) must be below the motive fluid inlet pressure to allow pump capacity to be achieved.

$$BP (\text{backpressure}) = (H \times 0.0981) + (P) + (P_f)$$

Height (H) in metres x 0.0981 plus pressure (P) bar g in the return line, plus downstream piping friction pressure drop (P_f) in bar. (P_f can be ignored if the downstream pipework is less than 100 metres to a non-flooded condensate return and has been sized to take into account the effect of flash steam at the heat exchanger's full load operating conditions.)

Dimensions/weight (approximate) in mm and kg

Size	A	B	C	D	E	F	G	H	I	Weight
DN20 x DN20	187	23	223	398	273	220	57	135	171	14

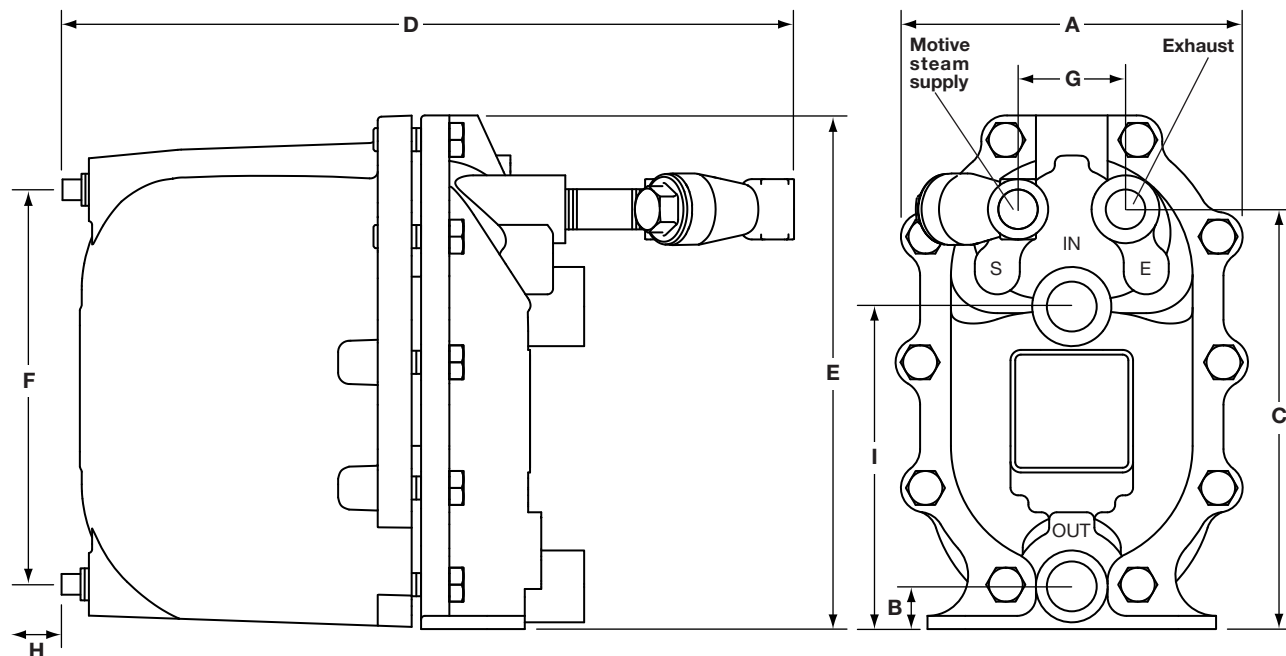

How to specify

The pump trap shall be a Spirax Sarco automatic pump trap type APT10-4.5 operated by steam to 4.5 bar g. No electrical energy shall be required. Body construction from SG iron (GGG 40.3 or ASTM A395) with a swing type inlet check valve and ball type outlet check valve. The internal trap mechanism shall contain a stainless steel float connected to an internal trap. The pump, trap and check valve mechanisms shall be incorporated into the same body envelope with no external seals or glands and shall be capable of operating with a minimum of 200 mm installation head from the base of the unit.

How to order: Example: 1 off Automatic pump trap, type APT10-4.5, DN20 x DN20, complete with motive supply strainer screwed BSP with BSP motive fluid connections.

Spare parts

The spare parts available are shown in solid outline. Parts drawn in broken line are not supplied as spares.

Available spares (see page 4 for part number identification)

A Cover gasket	2
B Inlet check valve	2, 12
C Spring and actuator arm	2, 14, 24
D Float	2, 5, 6, 21
E Trap and outlet check valve mechanism	2, 7, 8, 9, 10, 22, 23
F Inlet/exhaust valve and seat kit	2, 16, 17, 18, 19
G Motive supply strainer (Fig. 12 SG iron) - see separate literature	

Please note:

For customer convenience, spares are supplied in kits to ensure all the appropriate replacement parts are available e.g. when an inlet/exhaust valve and seat assembly is ordered, all replacement split pins, washers and gaskets will be provided in addition to the key components listed.

How to order spares

Always order spares by using the description given in the column headed 'Available spares' and state the size and type of unit.

Example: 1 off Inlet/exhaust valve and seat kit for a Spirax Sarco DN20 x DN20 APT10-4.5 automatic pump trap.

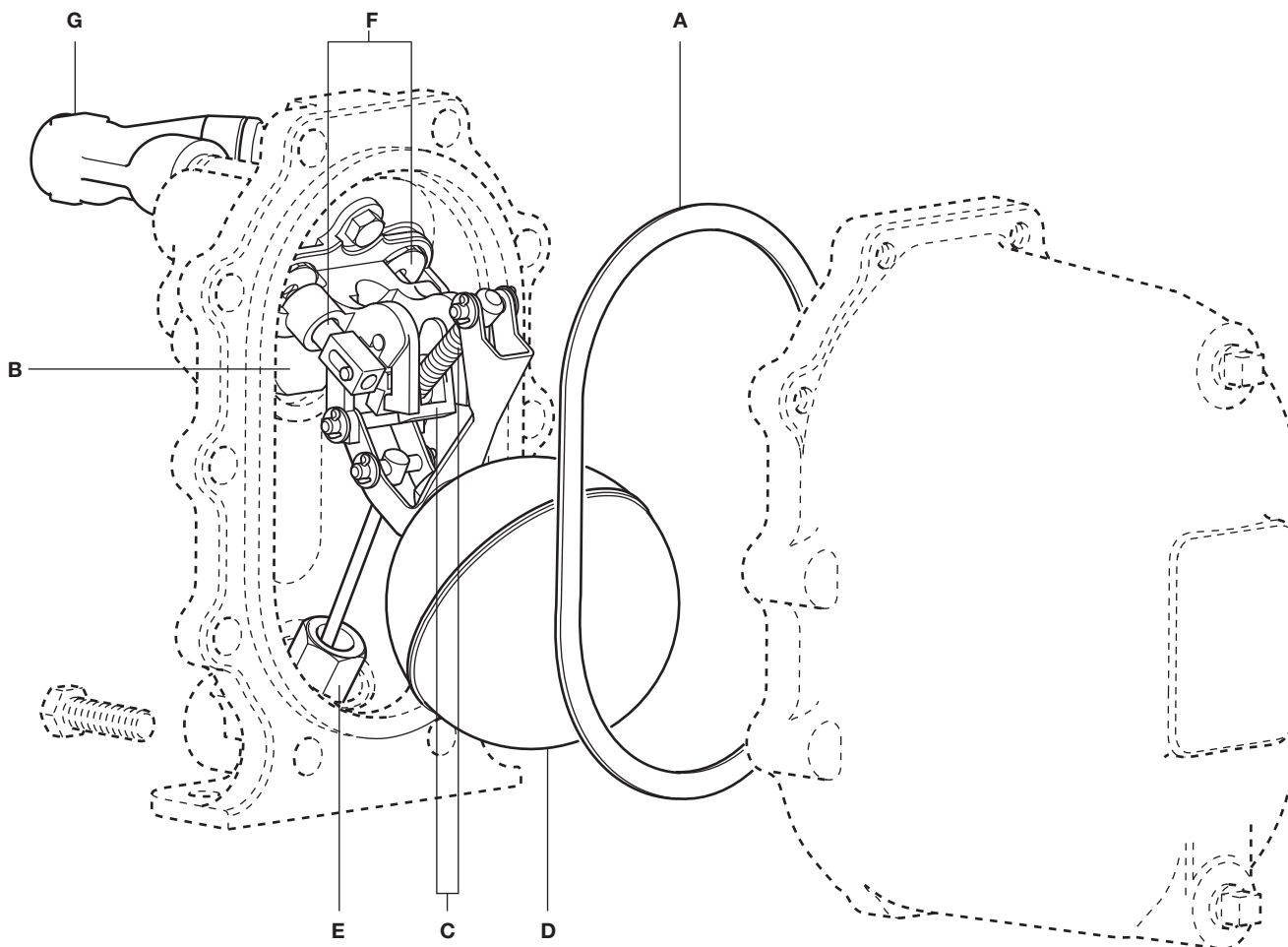

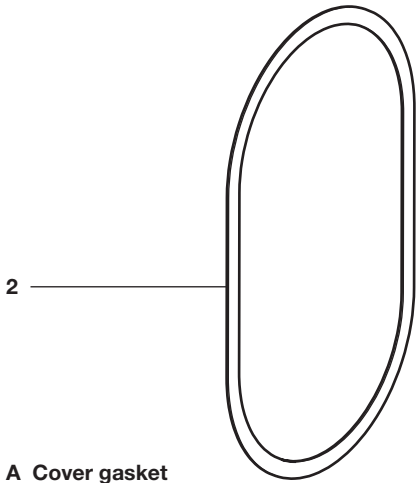

A Cover gasket

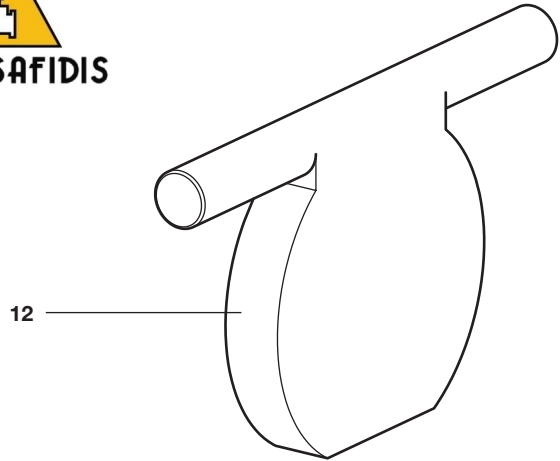

B Inlet check valve

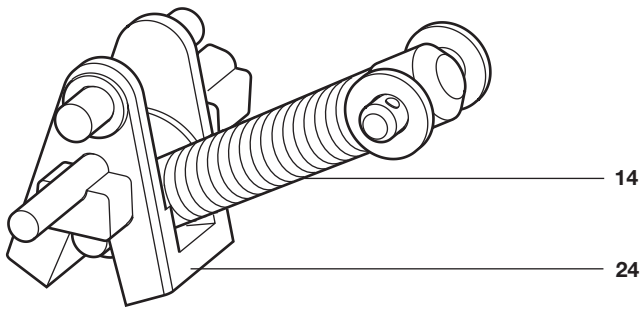

C Spring and actuator arm

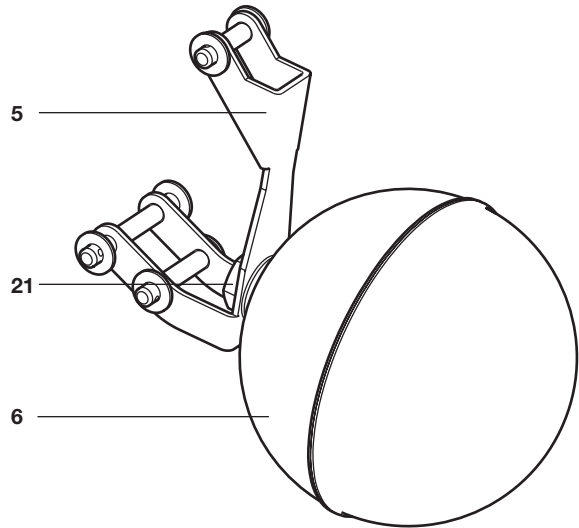

D Float

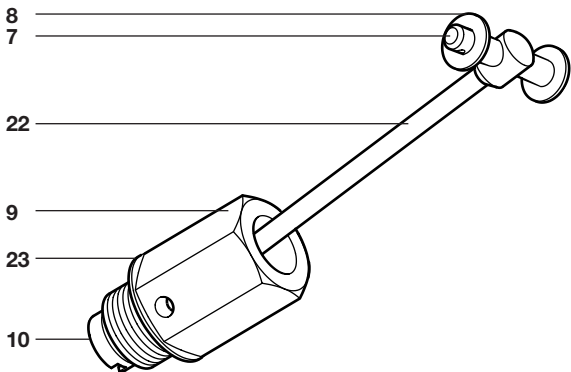

E Trap and outlet check valve mechanism

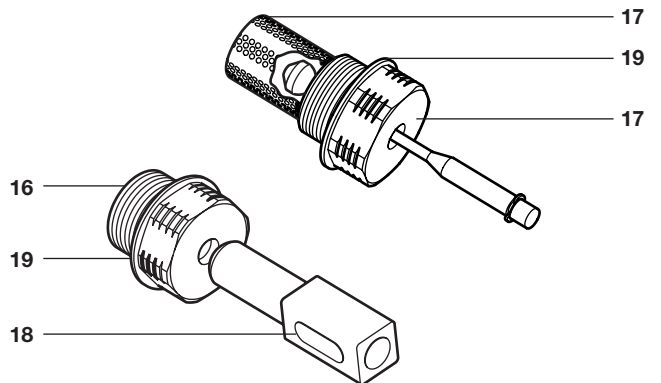

F Inlet/exhaust valve and seat kit

B Cover gasket

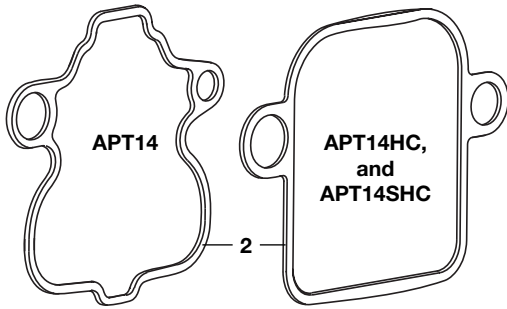

C Inlet check valve

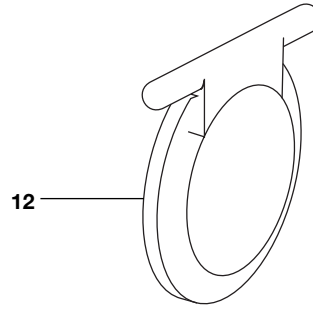

D Spring and actuator arm

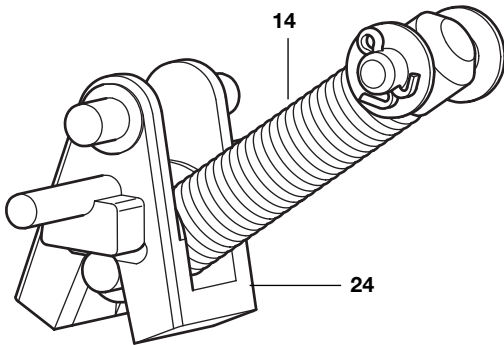

E Floats

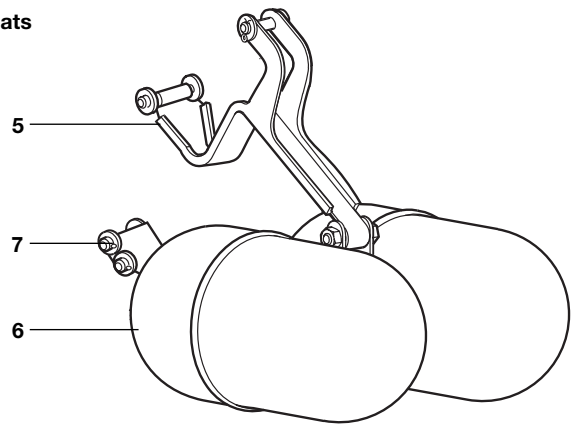

F Trap and outlet check valve mechanism

Note: Item 10 is not included for the APT14HC and APT14SHC

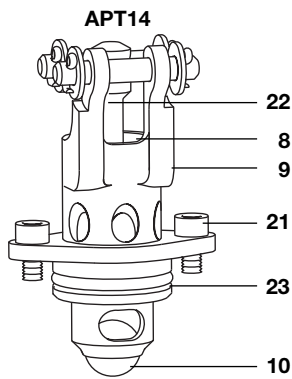

APT14HC and APT14SHC

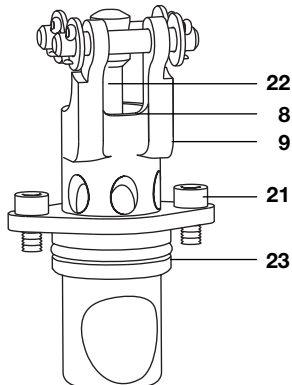

G Inlet / exhaust valve and seat kit

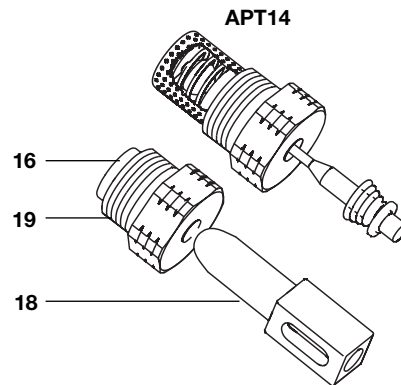

APT14HC and APT14SHC

