

2993xxA-1

GAS SOLENOID VALVES

with manual reset, Normally Open and Normally Closed

English

**MADE IN ITALY**

This document refers to solenoid valves:

- **GAS GAS** series marked **GECA**
- **VR** series marked **TECNOCONTROL**.

These solenoid valves have been designed to be combined with any gas detection system which sets off a warning signal to shut off the main delivery when an emergency situation is detected. All solenoid valves are reset manually in compliance with european standard EN 50194 governing gas detection system.

OPERATING PRINCIPLE

Normally Open (N.O.)

There is no electrical absorption during normal operation and so no part of the system undergoes wear; there is no annoying buzzing or vibrations, and energy is saved. However, when voltage is applied to the electromagnetic coil, the closure mechanism is released. To reset the solenoid valve, **check that the coil is not receiving current**.

- For the valves **550mbar** (from **DN15** to **DN50**) and from **550mbar/6bar** (from **DN65** to **DN100**) pull the "**Reset knob**".
- For the valves **6bar** (from **DN15** to **DN50**) unscrew the "**Protective plug**" and pull upwards the reset knob and after that screw the "**Protective plug**".

Normally Closed (N.C.)

The intrinsic accuracy of these models guarantee that gas will be cut off should the power supply fail. Consequently, a permanent power supply is required to keep the valve open. As soon as power across the coil is cut off, the valve shuts automatically. To avoid accidental closure, the valves are fitted with a mechanism that ignores interruptions to current of short duration (< 30msec). To reset the solenoid valve, **check that the coil is receiving current**.

- For the valves **550mbar** (from **DN15** to **DN50**) unscrew the "**Protective plug**" and pull upwards the reset knob and after that screw the "**Protective plug**".
- For the valves **550mbar/6bar** (from **DN65** to **DN100**) pull the "**Reset knob**".

1



Descrizione / Description

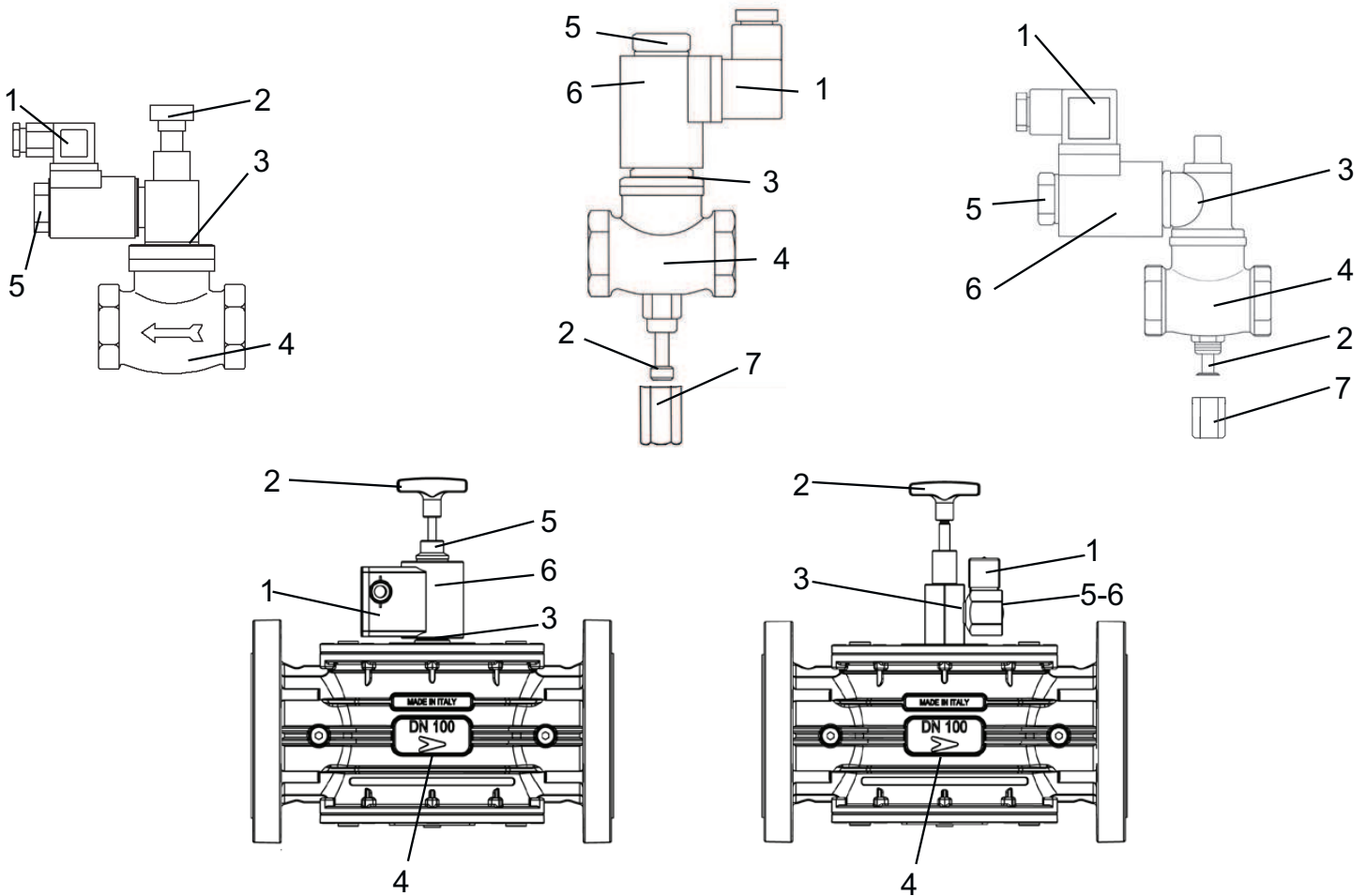

- 1 Connettore per il collegamento elettrico / *Electric connector*
- 2 Manopola di riarmo / *Reset knob*
- 3 Gruppo di scatto / *Release unit*
- 4 Corpo valvola / *Valve body*
- 5 Dado per il fissaggio della bobina / *Screw for coil clamp*
- 6 Bobina / *Coil*
- 7 Tappo di protezione / *Protective plug*

Simboli che identificano i connettori "raddrizzatori" (vedi tabella Timbratura bobina).
Identification symbol of the "rectifier" connectors (see table coil marking).

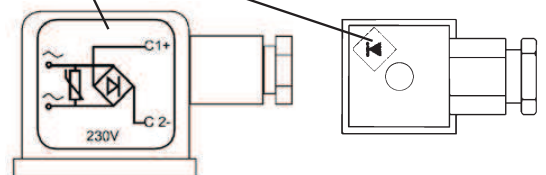

2



Normalmente aperte
Normaly Open

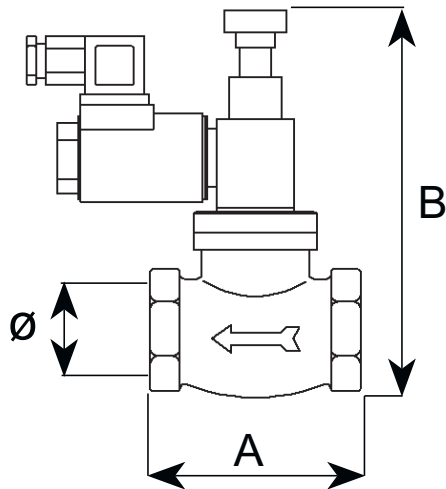

ϕ	A x B	PED	EN161
1/2"	60x120	-	-
3/4"	60x120	-	-
1"	78x125	✓	-
1" 1/4	114x174	✓	-
1" 1/2	114x174	✓	-
2"	139x182	✓	-

Normalmente Chiuse
Normaly Close

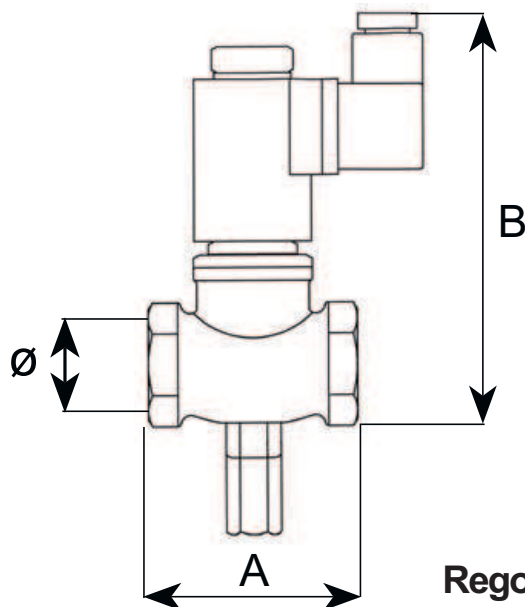

ϕ	A x B	PED	EN161
1/2"	60x135	✓	✓
3/4"	60x135	✓	✓
1"	78x160	✓	✓
1" 1/4	114x186	✓	✓
1" 1/2	114x186	✓	✓
2"	139x193	✓	✓

Regolamento 2016/426/EU (GAR) - Norma EN161
PED 2014/68/UE Directive

Misure di ingombro in mm - *Overall measurements in mm.*

Attacchi filettati secondo ISO 228/1 - *Threaded connections as ISO 228/1*

Corpo in ottone - *Body in brass.*

550 mbar

Dimensioni / Dimensions



Normalmente aperte
Normally Open

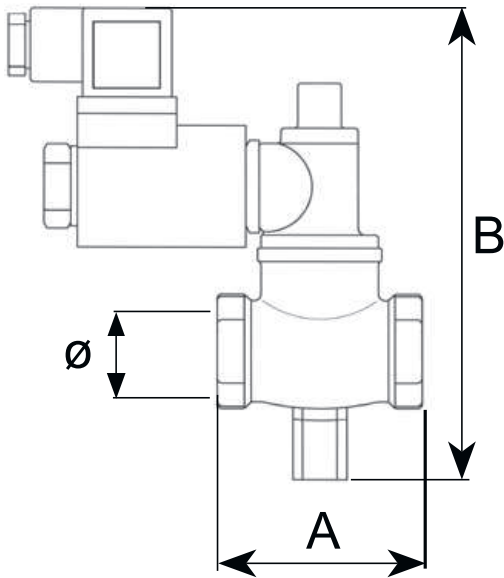

ϕ	A x B	PED	EN161
1/2"	60x140	-	-
3/4"	60x140	-	-
1"	78x165	✓	-
1" 1/4	114x195	✓	-
1" 1/2	114x195	✓	-
2"	139x210	✓	-

Normalmente Chiuse
Normally Close

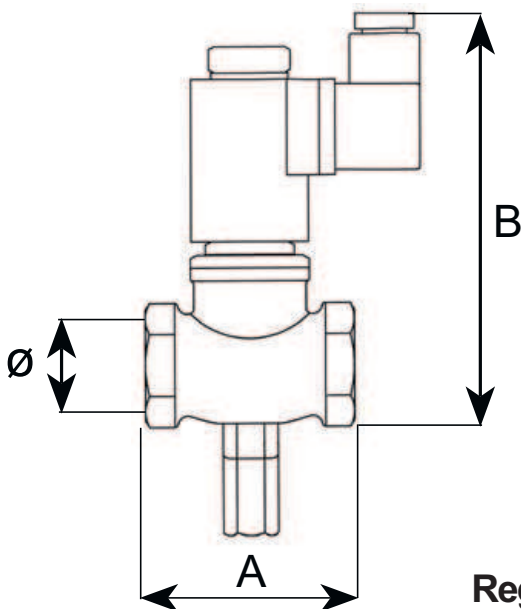

ϕ	A x B	PED	EN161
1/2"	60x135	✓	✓
3/4"	60x135	✓	✓
1"	78x160	✓	✓
1" 1/4	114x186	✓	✓
1" 1/2	114x186	✓	✓
2"	139x193	✓	✓

Regolamento 2016/426/EU (GAR) - Norma EN161
PED 2014/68/UE Directive

Misure di ingombro in mm - Overall measurements in mm.

Attacchi filettati secondo ISO 228/1 - Threaded connections as ISO 228/1

Corpo in ottone - Body in brass.

6bar

Normalmente aperte
Normally Open

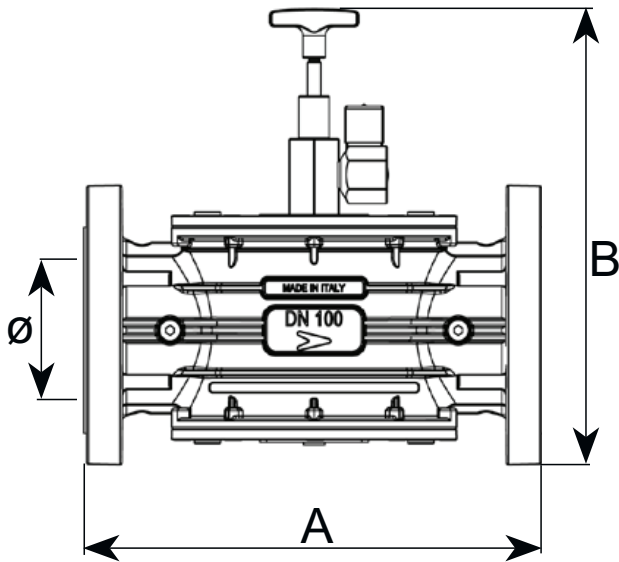

ϕ	A x B	PED	EN161
DN50 550mbar	230x180	✓	-
DN50 6bar	230x200	✓	-

DN65	350x346	✓	-
DN80	350x346	✓	-
DN100	350x346	✓	-

Normalmente Chiuse
Normally Close

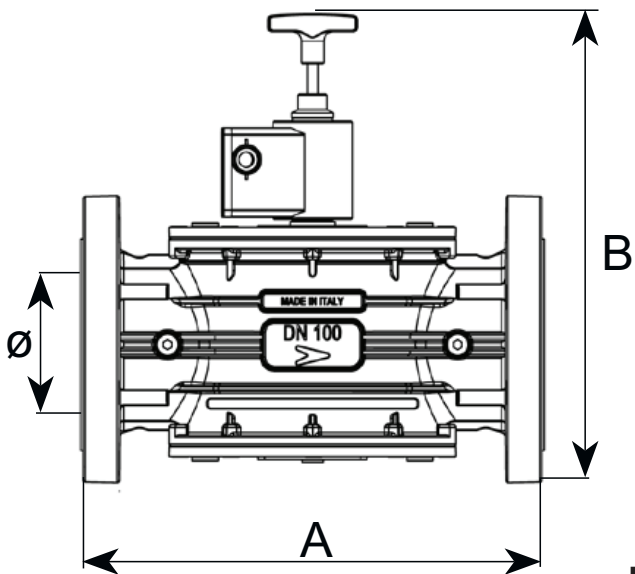

ϕ	A x B	PED	EN161
DN50 550mbar	230x193	✓	✓
DN50 6bar	230x193	✓	✓

DN65	350x348	✓	✓
DN80	350x348	✓	✓
DN100	350x348	✓	✓

**Regolamento 2016/426/EU (GAR) - Norma EN161
PED 2014/68/UE Directive**

Misure di ingombro in mm - *Overall measurements in mm.*
 Attacchi filettati secondo ISO 228/1 - *Threaded connections as ISO 228/1*
 Corpo in ottone - *Body in brass.*

550 mbar
6bar

Timbrature bobine da 1/2" a 2" / Coil marking from 1/2" to 2"

	12Vdc	12Vac	24Vdc	24Vac	110Vac-50/60Hz	230Vac-50/60Hz
N.A. N.O	12Vdc 19W	12Vac 17VA	24Vdc 19W	24Vac 17VA	110Vac 17VA	230Vac 17VA
N.C.	12Vdc 6W	12VRac 12W A	24Vdc 9W	24VRac 5W A	110 VRac 7,5W B	230 VRac 9W B

Timbrature bobine da DN65 a DN100 / Coil marking from DN65 to DN100

	12Vdc	12Vac	24Vdc	24Vac	110Vac-50/60Hz	230Vac-50/60Hz
N.A. N.O	12Vdc 19W	12VRac 17VA A	24Vdc 19W	24VRac 17VA A	110VRac 17VA B	230VRac 15W B
N.C.	-	-	-	-	-	230 VRac 15W C

A : con queste bobine (12-24Vac), utilizzare il connettore Cod. 2.180.2430 che funge da "ritardatore" e "raddrizzatore", presente nell'imballo.
: a particular (12-24Vac) connector must be associated to these coils which acts as a "delayer" and "rectifier" included in the packaging: Cod. 2.180.2430

B : con queste bobine (230-110Vac-50/60Hz), utilizzare il connettore Cod. 2.180.2429 che funge da "ritardatore" e "raddrizzatore", presente nell'imballo.
: a particular (230-110Vac-50/60Hz) connector must be associated to these coils which acts as a "delayer" and "rectifier" included in the packaging: Cod. 2.180.2429

C : con queste bobine (230Vac-50/60Hz), utilizzare il connettore Cod. 8.180.2555 che funge da "ritardatore" e "raddrizzatore", presente nell'imballo.
: a particular (230Vac-50/60Hz) connector must be associated to these coils which acts as a "delayer" and "rectifier" included in the packaging: Cod. 8.180.2555

Connettori - Electric connector

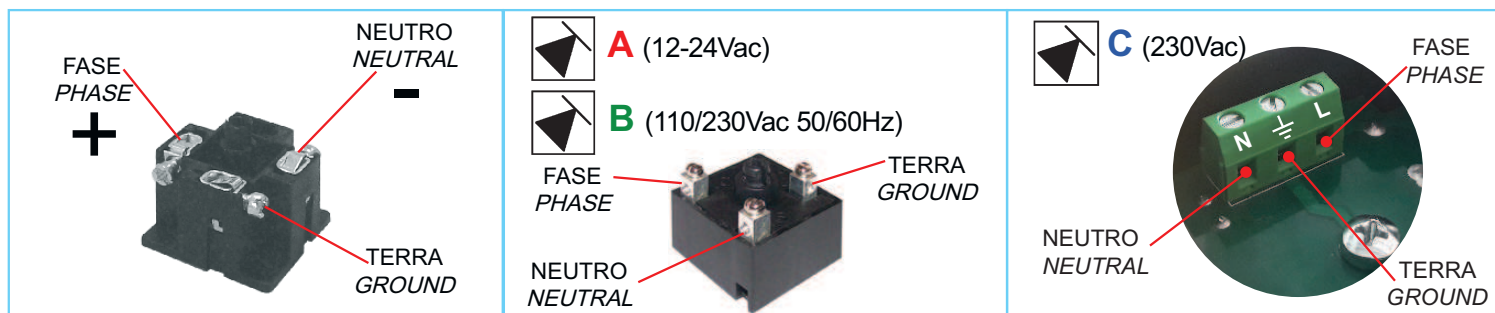

Manutenzione

Si consiglia di verificare periodicamente l'intervento dell'elettrovalvola. In caso di necessità, prima di effettuare qualsiasi operazione sull'elettrovalvola, accertarsi che all'interno della stessa non ci sia gas in pressione e che non sia alimentata elettricamente. Qualsiasi operazione di manutenzione dev'essere eseguita da personale qualificato.

Maintenance

The solenoid valve's intervention should be checked periodically. Should disassembly be necessary, make sure there is no gas under pressure inside the valve and that is not connected to the power supply before starting. All maintenance operations should be carried out by qualified personnel.



Installazione e posizionamento

Leggere attentamente il foglietto istruzioni prima dell'uso.

Questo dispositivo deve essere installato montando un filtro idoneo per gas (conforme alla norma UNI EN 161) a monte di esso, riferirsi inoltre alle leggi in vigore per una corretta installazione. L'elettrovalvola dev'essere installata con la freccia stampata sul corpo rivolta verso l'utenza a monte degli organi di regolazione, preferibilmente all'esterno dell'ambiente in cui è presente l'utenza e al riparo dagli agenti atmosferici.

Installation and positioning

Read instructions before use.

This device must be installed by fitting a suitable gas filter (according to UNI EN 161) upstream of it, also refer to the rules in force for proper installation. The solenoid valve must be positioned with the arrow stamped on the body turned towards the user appliance upstream of the regulation apparatus and preferably outside the measurement zone and repaired to the atmospheric agents.



Diagramma delle perdite di carico - Loss of head diagram



7

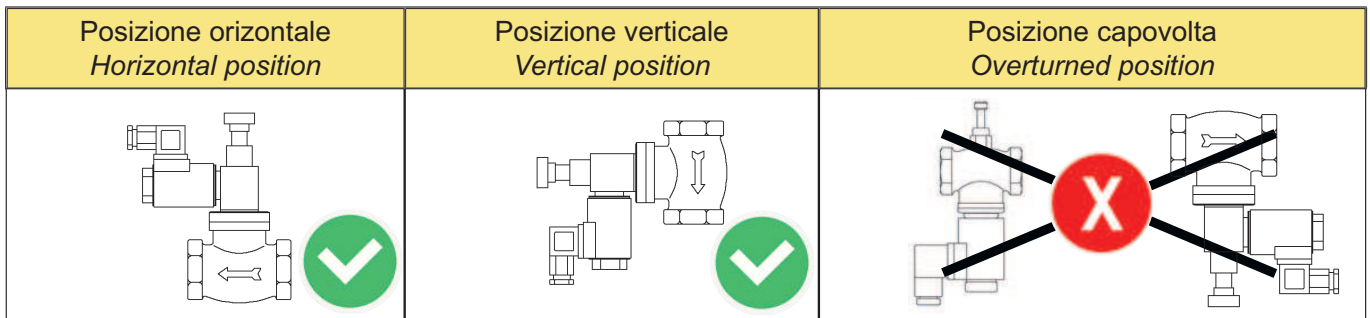
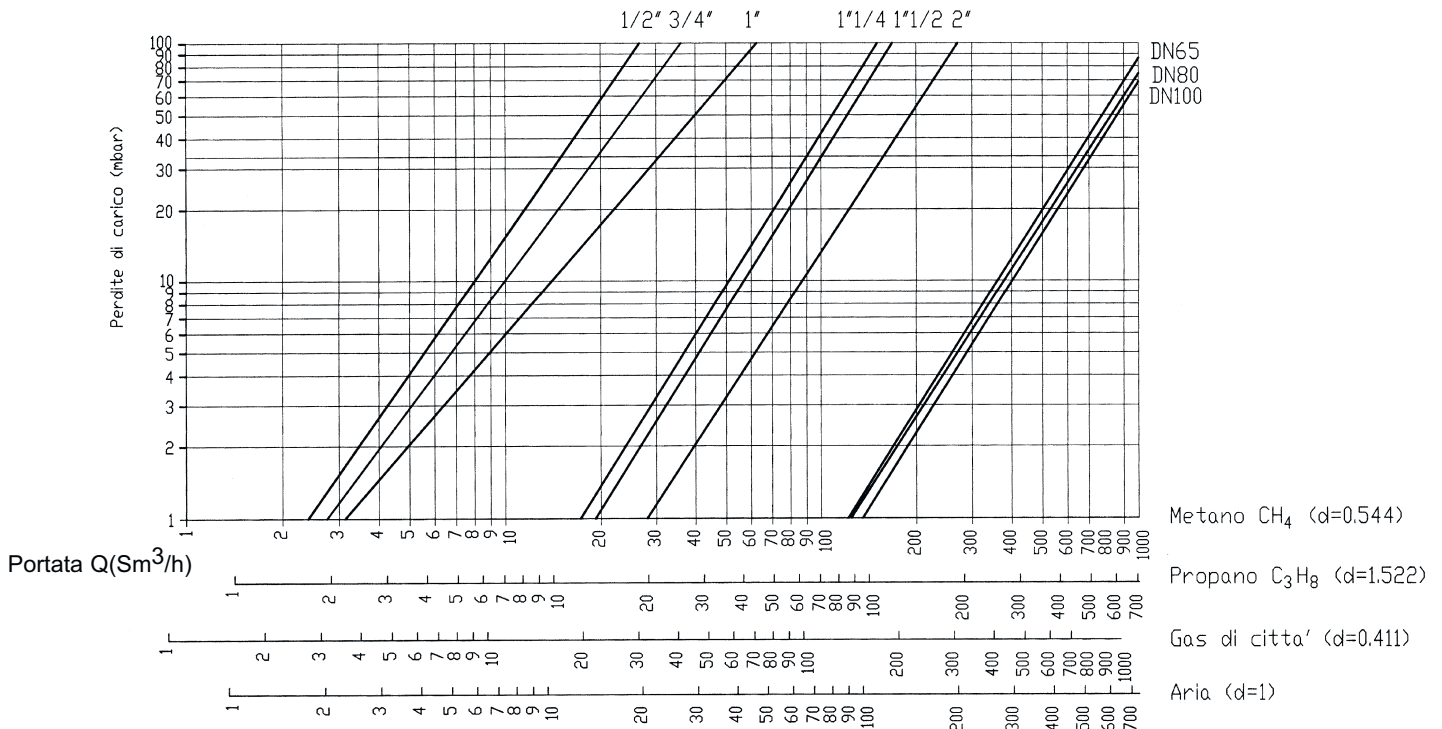

**DIRETTIVA 2012/19/UE (Rifiuti di Apparecchiature Elettriche ed Elettroniche - RAEE):**

Informazioni agli utenti:

L'etichetta con il cassonetto barrato presente sul prodotto indica che il prodotto non deve essere smaltito tramite la procedura normale di smaltimento dei rifiuti domestici. Per evitare eventuali danni all'ambiente e alla salute umana separare questo prodotto da altri rifiuti domestici in modo che possa venir riciclato in base alle procedure di rispetto ambientale. Per maggiori dettagli sui centri di raccolta disponibili, contattare l'ufficio governativo locale o il rivenditore del prodotto.

RAEE**Directive 2012/19/UE (Waste Electrical and Electronic Equipment - WEEE):**

Information for users:

The crossed out wheeled bin label that can be found on your product indicates that this product should not be disposed of via the normal household waste stream. To prevent possible harm to the environment or human health please separate this product from other waste streams to ensure that it can be recycled in an environmentally sound manner. For more details on available collection facilities please contact your local government office or the retailer where you purchased this product.

WEEE**CARATTERISTICHE TECNICHE/TECHNICAL CHARACTERISTICS**

- Pressione max/Max pressure: 550mbar / 6bar (a seconda del modello/in according to the model)
- Tempo di chiusura/Closing time: < 1 sec.
- Potenza elettrica/Power capacity:

tipo/type N.A./N.O.	12-24 (Vdc)	19W
	12-24-110-230 (Vac)	17VA -15W
tipo/type N.C.	12-24 (Vdc)	6W-9W
	12-24-110-230 (Vac)	5W-7,5W-9W-12W-15W
- Alimentazione elettrica/Power supply: 12Vdc, 12Vac, 24Vdc, 24Vac, 110Vac-50/60Hz, 230Vac-50/60Hz.
- Attacchi/Connections: da 1/2" a 2" filettati secondo ISO 228/1, da DN50 a DN100 flangiati secondo UNI2223
from 1/2" of 2" threaded as ISO 228/1, from DN50 of DN100 flanging as UNI 2223
- Grado di protezione elettrica/Level of electrical protection: IP65.
- Classe /Class: A
- Gruppo/Group: 2
- Temperatura di lavoro/Operating temperature: -15°C..... +60°C.
- Conforme / Approval: Direttiva 2014/68/UE (PED) (solo per modelli 6bar) /Directive 2014/68/UE (only for 6bar model).
Regolamento 2016/426/EU (GAR) - Norma EN161 / EU 2016/426 (GAR) Regulation - EN161Norm.

**Tecnocontrol**

Tecnocontrol Srl
Via Miglioli, n°47 20090 Segrate (MI)
Italy Tel. +39 02 26922890
www.tecnoccontrol.it

geca

GECA Srl
Via E. Fermi, n°98 25064 Gussago (BS)
Italy Tel. +39 030 3730218
www.gecasrl.it

La casa costruttrice riserva il diritto di apportare qualsiasi modifica, estetica o funzionale, senza preavviso alcuno ed in qualsiasi momento.
The manufacturer firm reserves the right to make any aesthetic or functional modification to the without prior notice at any time.

