



CHRYSSAFIDIS

## ΕΞΑΡΤΗΜΑΤΑ ΣΥΓΚΟΛΛΗΣΗΣ ΜΕ ΡΑΦΗ

### BUTT-WELDING FITTINGS WITH SEAM

Σελίδα Τιμοκαταλόγου - Pricelist page: A.15

Προδιαγραφή - Specification	EN 10253-1 / DIN 2605 Type 3 (r=1,5D)
Υλικό - Material	R. St 37.0 W
Τεχνικό Έντυπο - Data Sheet	<a href="#">1711xxA</a>

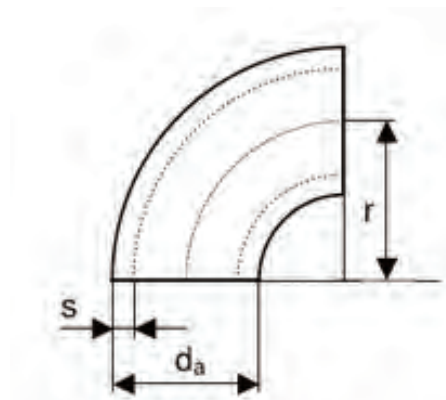

#### Καμπύλες Οξυγόνου 90°

##### Welding Elbows 90°

Κωδικός Code	Εξωτ. Διάμ. × Πάχος Ext. Dia. × Thickness mm × mm	Μέση Ακτίνα Mean Radius r mm	Βάρος Weight ≈ kg
171104	21,3 × 2,0	29,0	0,04
171106	26,9 × 2,3	29,0	0,07
171110	33,7 × 2,6	38,0	0,12
171112	38,0 × 2,6	45,0	0,16
171114	42,4 × 2,6	48,0	0,19
171118	48,3 × 2,6	57,0	0,27
171124	60,3 × 2,9	76,0	0,49
171128	70,0 × 2,9	92,0	0,70
171130	76,1 × 2,9	95,0	0,79
171134	88,9 × 3,2	114,0	1,22
171138	101,6 × 3,6	133,0	1,82
171140	108,0 × 3,6	142,5	2,07
171142	114,3 × 3,6	152,0	2,35
171146	127,0 × 4,0	171,0	3,26
171148	133,0 × 4,0	181,0	3,62
171150	139,7 × 4,0	190,0	4,00
171154	159,0 × 4,5	216,0	5,82
171156	168,3 × 4,5	229,0	6,52
171162	219,1 × 6,3	305,0	15,8
171168	273,0 × 6,3	381,0	24,8
171170	323,9 × 7,1	457,0	40,0



#### Καμπύλες Οξυγόνου 90° Γαλβανισμένες

##### Welding Elbows 90° Galvanized

Κωδικός Code	Εξωτ. Διάμ. × Πάχος Ext. Dia. × Thickness mm × mm	Μέση Ακτίνα Mean Radius r mm
171304	21,3 × 2,0	29,0
171306	26,9 × 2,3	29,0
171310	33,7 × 2,6	38,0
171314	42,4 × 2,6	48,0
171318	48,3 × 2,6	57,0
171324	60,3 × 2,9	76,0
171330	76,1 × 2,9	95,0
171334	88,9 × 3,2	114,0
171342	114,3 × 3,6	152,0
171350	139,7 × 4,0	190,0
171354	159,0 × 4,5	216,0
171356	168,3 × 4,5	229,0
171362	219,1 × 6,3	305,0
171368	273,0 × 6,3	381,0