

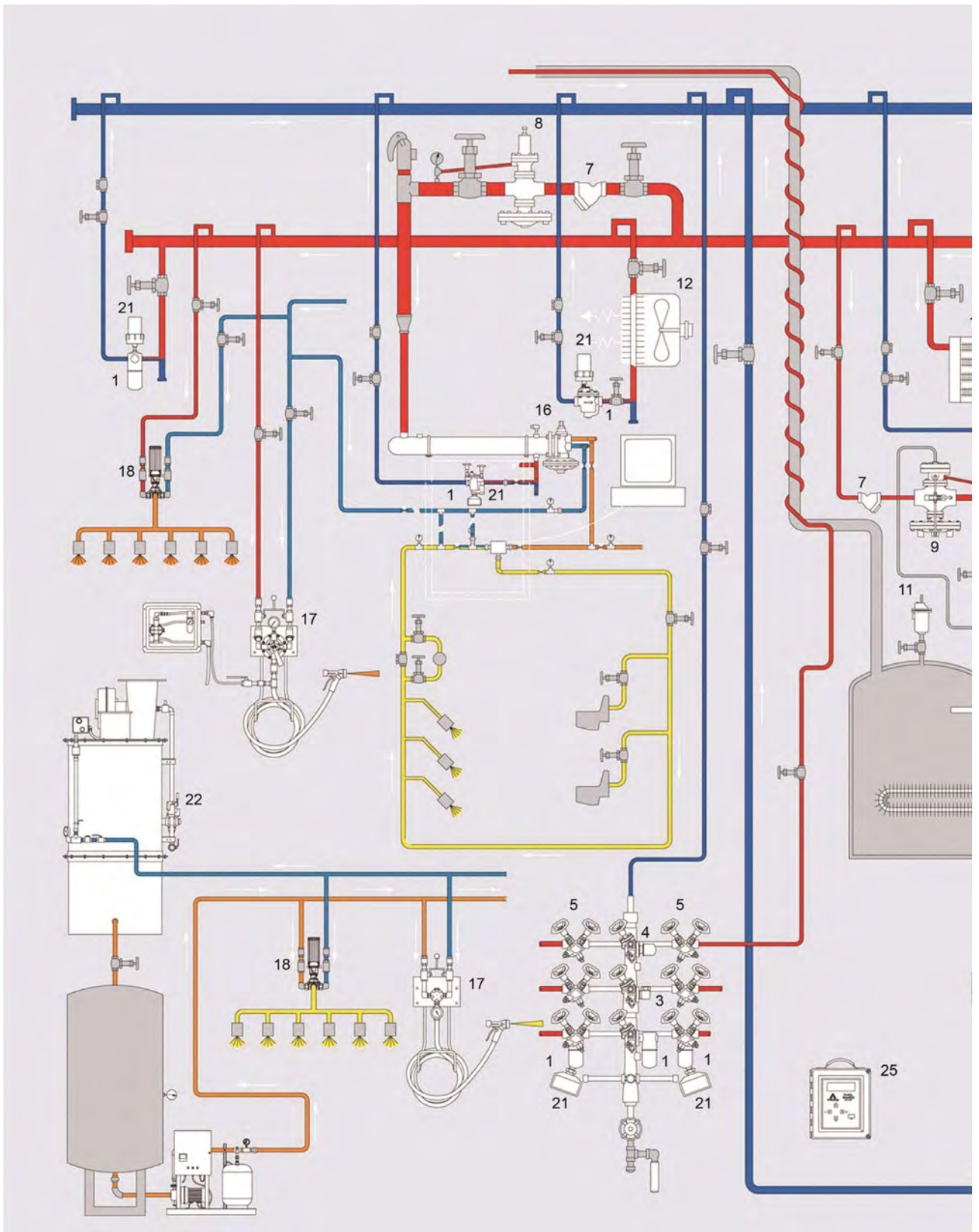

CHRYSSAFIDIS



- | | | |
|---------------------------------------|--|---|
| 1. Inverted Bucket Steam Trap | 5. Steam Trap Station | 9. Temperature Regulator |
| 2. Float Thermostatic Steam Trap | 6. Mechanical Pump (Pressure Powered Pumping Trap) | 10. Automatic Vacuum Breaker - Air Vent |
| 3. Thermodynamic Steam Trap | 7. Y-Strainer | 11. Air Vent |
| 4. Bimetallic Thermostatic Steam Trap | 8. Pressure Reducing Valve | 12. Unit Heater |